

**00785**

1964/05/28

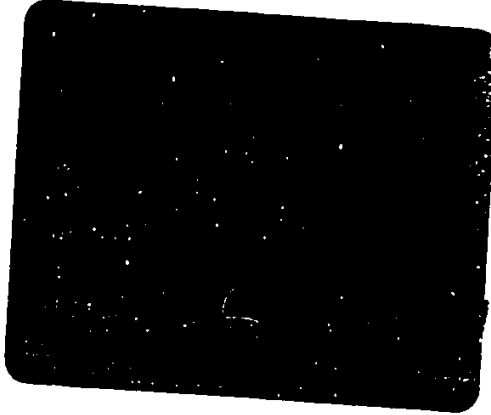

Proceedings  
of the  
Special Projects Office  
Steering Task Group

Task II - Monitor the Fleet Ballistic  
Missile Development Program  
43rd Meeting - 27, 28 May 1964

This document contains information affecting the national defense of the United States within the meaning of the Espionage Laws, Title 18, U. S. C., Sections 793 and 794. The transmission or the revelation of its contents in any manner to an unauthorized person is prohibited by law.

Prepared by: *Clayton E. Evans*  
Reviewed by: *S. S. Sedice*  
Approved by: *Revering Smith*

40

DECLASSIFIED ON 25 JULY 1995 IN  
ACCORDANCE WITH OPNAVINST S5513.5B  
ENCLOSURE (27).

5050

10 JUL '64 1010-SP



TABLE OF CONTENTS

Introduction	
Admiral Galantin	3
Command Communications Committee	
Captain Dudley	5
Navigation Committee	
Captain Gooding	21
Submarine Design Committee	
Commander Skinner	51
Launching and Handling Committee	
Captain Hammerstone	69
Mr. Herbert Cabral	97
Re-entry Body Committee	
Commander Julian	107
Missile Committee	
Mr. Larry Kitchen	159
Captain Christman	177
Fire Control and Guidance Committee	
Captain O'Neil	221
Mr. Richard Coleman	231
Mr. Wilford Lewis	259
Systems Appraisal Committee	
Dr. John Craven	275
Mr. Robert Miller	285



## INTRODUCTION

Admiral Galantin welcomed the Steering Task Group and reported on recent flight tests, as follows:

There were three A3X flights --

A3X-53 from the USS OBSERVATION ISLAND was a complete success.

The next one from the OBSERVATION ISLAND was a failure because of the extreme roll-out required.

The third firing had a fix incorporated to improve the roll-out capability and this was a complete success.

There were also three A2P DASO firings, all of which were successful. One of these was the first surfaced submarine firing which followed within thirty minutes a submerged firing. Much credit is due to the officers and crew who handled these different modes so well and so promptly.

These shots give us a total of 32 out of 37 successful A2 DASO's for 86.5 percent.

Admiral Galantin then expressed his concern over the A3 second stage low-density, or variable density, problem. A great deal of effort is being expended to resolve the problem even though no failures have resulted from variable density propellant or propellant separation. The problem is somewhat of a phantom but is a threat hanging over the program if it cannot be satisfactorily explained.

On the SSB(N) 598 overhaul, Admiral Galantin reported that she is due in New London on 15 June and that there is no contract yet with Electric Boat. SP and BuShips had budgeted about \$28,000,000 for this overhaul, but because of the amount of work occasioned by the

## INTRODUCTION

submarine safety program and the retrofit to accommodate the A3 missile, the estimate is now about \$42,000,000. This is a severe funding problem that is receiving considerable attention and Admiral Galantin stated that he would welcome the thoughts of the STG.

COMMAND COMMUNICATIONS COMMITTEE  
REPORT DISCUSSION

"Gentlemen, the Communications Committee Report today is our attempt to define a balance sheet," began Captain Dudley, "between the R&D monies we have spent and the yield we have received for these expenditures. While the report was originally written by me, it has received full treatment at the hands of my committee and, if anything, is now rather more representative of their views than of my own.

"When we start discussing the question of yield, or money's worth, from R&D efforts such as we have engaged in, we must first develop some criteria for the efforts and from them formulate a way of rating the yield received. We had trouble with this, for the committee members at times held sharply divergent views about some of these values; on some points unanimous conclusions could not be reached.

"In figure 1, we have some of the points in our rationale for this review. Most significant was the importance of the POLARIS Program itself, and its urgency and high priority. I do not think that there has been any program with higher priority during our time span. On this basis, our general conclusion was that we had been able to accomplish great improvements working with existing systems, but that we had not been able to do nearly as well in implementing new systems or new capabilities, or new concepts of doing things. Here the big problem was simply acceptance by the Navy; frequently we had reason to voice some concern about what it was that the Navy wanted.

"One problem here was that the ground rules sometimes changed right under our feet. A program would be started because of a need or even a requirement for the capability that would be offered; but when the capability was gained, then the rules would change and there was no longer a requirement for the capability. Here, POSAC/SUCCESS is a good example. There was a definite need for such a program even though CNO had not committed this need to writing. Once we had

COMMUNICATIONS R&D YIELD REPORT

RATIONALE:

- A. POLARIS "TOP PRIORITY" SYSTEM
- B. IMPROVEMENT IN EXISTING SYSTEMS -- SUCCESSFUL  
IMPLEMENTATION OF NEW SYSTEMS -- UNSUCCESSFUL
- C. CHANGE IN GROUND RULES
- D. RESEARCH TO DETERMINE GOALS, ESTABLISH  
PARAMETERS, ET CETERA
- E. HIGH YIELD -- TECHNICALLY
- F. LACK OF OPERATIONAL "APPEAL"
- G. NAVY NOT CONCERNED ABOUT JAMMING
- H. VARIOUS WAYS OF EXPRESSING YIELD
- I. OVERHEAD COSTS

Figure 1

the capability accomplished, then other voices told us that there was no requirement for it.

"In many of the areas of concern, it was necessary to do some research merely to determine what could be reasonable goals within the area. It was necessary, in some cases, to conduct research and to determine what reasonable goals to expect, what costs to expect, and what parameters to establish for further research along hardware lines. This included the determination in some cases that there was no application of an item to POLARIS Communications. In some of these areas of no application, we felt that the expenditures were fully justified. An example of this would be the seismic techniques of communication through the Earth. In other areas, we concluded that a much earlier decision could have been made to reject the project. An example of this is WHISPER, the cable direct to the submarine while on patrol station.

"The non-operational, technical, members of the Committee felt very strongly that much of our effort produced an R&D yield in terms of technical successes or ways to accomplish technical objectives that were not known before, and thus improved the state of the art. This would be an additional yield or collateral asset, in providing information for the technical storehouse of the nation, although not necessarily POLARIS. In their opinion, successful research and development occurred even though the effort had no specific application to POLARIS Communications.

"I should mention here that our committee has both technical civilian members from industry and Navy operational representatives in CNO, SUBLANT, SUBPAC, and so forth. In retrospect, the operational members considered that many of the items researched had little operational appeal initially, and would never have been supported to any extent if operational requirements had been better understood.

"With reference to anti-jam protection, the Committee believes that the non-acceptance of proposed A/J systems suggests that the Navy is not as concerned about jamming as the Committee or the Special Projects Office and is willing to wait for a system which will encompass the entire Fleet requirement. The Committee has urged A/J protection as a form of insurance; we have urged an interim A/J system to gain both time and insurance.

"There are several ways to express R&D yield. Each way must be considered on its own merits with its limitations recognized. Yield in terms of R&D money spent versus production dollars required to provide a fleet capability can be misleading. For example, the floating wire program only cost \$400,000 in R&D but it provided a relatively inexpensive unit that considerably increased receiving capabilities on board the SSB(N)'s.

"There was general agreement that in any program of this nature, support work usually runs from 10 to 20% of the program. In this review, it was apparent that the 18% figure spent for study and supportive research efforts that did not contribute directly to the hardware or to



COMMUNICATIONS R&D YIELD REPORT

CATEGORIES	MONIES EXPENDED (\$M)
ANTENNA IMPROVEMENT	6.0
TRANSPORTABLE/MOBILE	11.4
VLF A/J	14.3
SECURE SHIP-TO-SHORE	14.4
ELF	12.1
NON-ELECTROMAGNETIC	19.8
IN EXTREMIS	4.1
SUPPORT	18.1

Figure 2

protective systems for the Fleet was considered to be reasonable.

"For our review, the program was divided into the eight categories shown in figure 2. In discussing the content of figure 2, I shall merely tack my comments onto the subject entry:

Antenna Improvement: We developed the floating wire antenna as well as improved whip, loop, and buoy antennas; our efforts were thoroughly successful in that we provided a notable improvement in reliability and capability at a relatively low R&D cost.

Transportable/Mobile: We developed three high flying systems and are now implementing a successful program that will open new avenues to survivability. For two of these techniques, the R&D system will be used in the operational area.

VLF/Anti-Jam: Here we have spent more and accomplished less in terms of fleet acceptability. We spent 12 million in working up several systems which are now on the shelf even though they were successful; we spent another 2 million on

a system which gave us nothing in added capabilities. Technically, much of our effort was successful. One of the working systems, BAGATELLE, would have cost over 100 million dollars to implement, and was not accepted, as other working systems also were not accepted, operationally. We did learn one important thing: The cost for A/J protection per decibel is rather high. The lack of success in this area seems to be due more to management than to technology.

Secure Ship-Shore: We have two programs under development that seem to ensure definite capabilities for the SSB(N)'s once they are put into operation. Here we feel reasonably, or 66%, successful.

ELF: We are pleased with the success and the singular abilities of the ELF system, which has been a totally new concept starting right with the basic research. It is survivable, has world-wide coverage, can function in a nuclear environment, releases the submarine from depth/speed restrictions to a substantial degree, and has proven itself in tests. We wait only on a word from CNO to pursue further development and implementation.

Non-Electromagnetic: Here we have produced some technically sound hardware and techniques but no acceptable communication system. Both POSAC/SUCCESS and the radio acoustic buoy are successful items now on the shelf; they cost about 5 million dollars between them. We have spent 14 million dollars on two systems and neither has been acceptable so far: we spent 2.6 million dollars on WHISPER, but dropped it.

In Extremis: This effort has cost us 4 million dollars and is still underway. We feel this will be a successful effort and we have been authorized to install it on the submarines, which is equivalent to at least a partial operational acceptance.

Support: This covers a multitude of items in gaining information needed to back up the other programs. Included are noise studies, wave propagation studies, operational analyses, and many



COMMUNICATIONS R&D YIELD REPORT

CAPABILITIES	MONIES EXPENDED
DEPTH-SPEED	\$34.3 M
PHYSICAL SURVIVABILITY	\$31.2 M
JAMMING SURVIVABILITY	\$12.4 M
SECURE SHIP-TO-SHORE	\$14.4 M

Figure 3

other basic researches. These costs are necessary and they have been, we feel, successful in their purpose.

Figure 3 needs some numbers added from the earlier material. For example we can break down the Depth / Speed costs as follows:

Accepted Projects . . . . .	\$ 5. Million
Pending Projects . . . . .	12. Million
Rejected Projects . . . . .	17. Million

Assuming ELF to be successful, we are fifty percent successful.

"The cost breakdowns here do not match the totals of figure 3 because our efforts fit into more than one category. Next, we can claim little return for what we spent on Jamming Survivability except the A/J protection found in the Secure HF system. We are continuing work, but have implemented nothing.

"We have spent \$31.2 million on Physical Survivability. TACAMO NOMAD and SHIPBOARD VLF can give marginal survivability, as can BAGATELLE which has been dropped. ELF will improve survivability if it is used. Here our efforts can be defined as follows:

Successful Projects . . . . .	\$11. Million
Pending Projects . . . . .	12. Million
Continuing Projects . . . . .	5. Million
Unacceptable Projects . . . . .	3. Million





COMMAND COMMUNICATIONS COMMITTEE DISCUSSION

"The costs for Secure Ship-Shore system can be defined as follows:

Accepted Projects . . . . .	\$3. Million
Continuing Projects . . . . .	7. Million
Unacceptable Projects . . . . .	5. Million

Here we feel that our success can be rated at 66 percent.

"Looking at the yield by dollar value of what has been implemented in the fleet, a total of \$20 million of R&D has led to a \$93 million expenditure of O&M money and shipbuilding funds assuming a 41-boat fleet. This is projected money that will be spent, as the 41-boat program has been currently approved. In other words, it only takes \$20 million of R&D effort to result in \$93 million implementation in the fleet. If all of the technically sound capability-producing systems had been implemented, we would have an outlay of about 300 to 600 million dollars for our \$100 million of R&D.

"To summarize: (a) The conclusions of the Committee were that the POLARIS Communications R&D effort was instituted on a high priority crash program basis to provide an adequate communications capability in a time scale consistent with the FBM deployment schedule. As such, the program proceeded along many technical paths with minimal operational guidelines as ground rules. In many cases, the operational guidance provided changed during the development program.

(b) The R&D effort has established the design limits on the POLARIS Communication System and the Navy is now in a position to define the communications system requirements on the basis of sound technical information. This R&D effort has produced many techniques, developed considerable hardware, advanced the state of the art, and provided very necessary information on what techniques are required to meet depth/speed requirements and the definition of such techniques.

(c) This R&D effort in general has not produced hardware in fleet operational use commensurate to the R&D expenditures. The reasons for this include the changing of ground rules during a program, the pursuing of programs which are technically satisfactory but operationally not accepted, the reluctance of the Navy to implement high cost production programs for POLARIS communications, and lastly the lack of sufficient specific requirements for POLARIS communications which the



Navy will pay for when developed. Therefore, from an operational and managerial point of view, the R&D yield is something less than satisfactory; as a matter of fact, the yield is poor.

(d) The Navy should clearly define the operational requirements as they relate to POLARIS Command and Control Communications, acknowledging the well-founded technical limitations and progress in the state of the art, and recognizing that the implementation of methods to communicate with freely maneuvering submarines in a post-strike nuclear environment is costly, and then proceed to develop and implement the systems needed to provide the required capability.

(e) Yield will continue to be poor because there is not now available a Navy position on the enemy threat to POLARIS Command Communications, nor on the expenditure, relative to the capital investment and upkeep of the entire FBM Weapon System, needed to counter such a threat. To be explicit, CNO, Special Projects Office and the Committee do not agree on the following:

(1) That the enemy has a technical capability and may be willing to expend as much on jamming and/or destroying command communications as the U. S. invests in building it.

(2) Strengthening POLARIS Command Communications for the FBM fleet is an expenditure equal to one or more vessels of the fleet.

"Even if agreements were reached on the foregoing, the Committee itself would need further guidance from the Navy on the acceptable trade-offs among depth/speed, data rate, survivability, jam resistance, shared service, and investment. At this time, there is no known system that meets all of the requirements, nor is one now foreseen. It is not possible to design a compromise system without knowing the acceptable trade-offs.

"That completes the report from the Committee. There is considerable backup material generated from this effort which has been put in a book and will probably be filed in the archives in case someone ever asks in the future about what happened to that \$100 million."

Dr. Kirchner observed that the rate of expenditure over a five-year period was certainly not excessive and that much justification would be available if the filed papers included some discussion of the beneficial side-effects or "spin-off" from all the investigations performed, and that someone ought to do an analysis of the programs that should be pursued outside of SP's aegis.

"We have not done any such study," replied Captain Dudley. "When I mentioned the technical information developed, this is information which at present is only applicable to the Special Projects Office, even though it includes techniques that were uncovered and may at some future date have some usefulness. For example, in the WHISPER program, using a cable to the submarine, considerable research was done here with reference to underwater cables, laying cables, and so forth. I am sure that this information has led contractors to other, similar techniques which they may be developing for the Navy or for industry.

"The ELF system is an entire area which no one had gone into before. SP is the only organization to actually set up and operate a test ELF system which produced results; we have developed parameters which completely define what you can get from an ELF system and how much it costs and so forth. This had never been done before. I do not know whether anyone in the future will find use for an ELF system other than the Navy. The Air Force might very well, for example.

Dr. Kirchner observed that the estimated 50% success rating which Communications had given itself was merely looking through the periscope of the POLARIS Program and Mr. Peterson concurred, noting that the rating seemed unduly harsh and demanding, especially when one considers that one of the greater ends of R&D effort is to determine those things which need not be implemented, need not be purchased, need not be further investigated even though they might be successful. Captain Dudley observed that these remarks were almost identical to those of the dissenting civilian scientists on his committee.

"I do not think that the point of an R&D program," added Mr. Peterson, "should be the assumption that 'If we spend X-dollars for

R&D, our criteria of success ought to be the ability to get O&M to spend 10-X dollars for hardware and implementation.' I think the best R&D may work the other way around -- we spend X-dollars now so that we will not have to spend any O&M dollars later."

"Nonetheless, the hardware expenditure is a pretty good measure of whether this effort has improved the system," said Captain Sanger. "Certainly if there is no hardware, there is no improvement."

"One basic point we seem to miss here," said Mr. Morton, "is that we cannot really tell whether we are successful or not until the Navy provides some agreed-upon operational requirements. When these requirements come through, it may mean that some of the shelved systems will be brought back into use. We certainly cannot measure success in terms of the operational requirements we presently have."

Mr. Stevenson observed that Captain Dudley's caution was justified, for it seemed highly possible that some future GAO auditor might pursue a lot of inquiry into the various projects pursued and why these monies were spent in that fashion. This report that Communications is preparing is the only material that may be available to justify the efforts, and it should contain, as Dr. Kirchner suggested, comments about the things that were successful, unused by the Navy, and yet still potentially valuable in future developments. Dr. Kirchner agreed, adding that it could serve more purposes than merely soothing some future GAO interest. Mr. Peterson added that ELF could, if so presented, look like the Navy had merely thrown away a lot of money or it could, presented in a better fashion, look like a commendable and valuable piece of basic research.

"I must also disagree with your harsh judgment about your success," said Dr. Mechlin, "about R&D values in either military or industrial areas. We have too often seen technically successful developments that are never implemented -- and this can be for many and various reasons."

"But actually we are looking for some indicator about the advisability of spending future monies in some particular area," observed

Captain Sanger, "and we should gain this from any R&D effort."

"Obviously there are some requirements that need to be met, such as the need for improving depth/speed capability, that CNO cannot help but agree to," said Mr. Peterson.

"Within limitations," said Captain Dudley. "If we can provide this capability for \$10,000 then they are interested. If it costs a hundred times that much, or a thousand, then CNO loses interest."

"That comes within my point," continued Mr. Peterson, "because there are certainly four or five broad types of approved capability which cannot per se be argued or contested and which were investigated by some of the best minds that Communications could assemble for the task of exploring the possibilities of coming up with something better within these four or five categories. Now one of the reasons for the R&D is this: To determine that improvements can be had within these categories but that some of these improvements are not worth the money they would cost. This is one of the best reasons for doing R&D work, and I certainly do not think that we should be concerned simply because we have learned that improvements do cost more than they may be worth to the program right now.

"I can grant that some of these things would not have been done, and some of the monies not spent, if CNO had spelled out their requirements completely at the outset of the effort, telling us what they wanted and what they needed and what they would pay for. But we need to remember that frequently CNO's decisions may well have been based on the progress of our R&D efforts."

Dr. Barrow noted that some of the major difficulties here lie outside of SP in that some of SP's developments become organizationally and operationally involved in other areas of the Navy. "If these problems were simple," continued Dr. Barrow, "then someone would certainly write up a binding requirement that would let us know where we stand. It is not simple, and instead of certain requirements we find we must start with assumptions. We may assume that some idea will be useful, but we do not know and we will not find out until after we



have accomplished it whether or not it is important enough to procure."

"I grant that many of the requirements given us were expressed as generalities," replied Captain Dudley, "such as 'we'd like to be able to communicate through a jamming environment.' That is one judgment and one decision. Then we do the work on this effort and come in with our results -- 'you can have this capability within these limits for this much money.' Then they make the next judgment and the next decision -- either they like it at the price quoted or they feel the capability is not worth the price."

"Nonetheless you should not feel guilty about unacceptable R&D work," stated Mr. Peterson. "I suspect the general requirement is a necessity; I doubt if the best brains in CNO would come up with a truly useful specific requirement for something in the SP Communications area because most of these investigations take us into previously dim or unknown areas. CNO people would be hard pressed to come up with actual numbers or even the possible limits of the actual numbers. The money spent here for R&D gives us all, CNO included, a much better feel for the entire affair, allows us to make better definitions, to set limits and even make sensible trade-offs."

"In a sense, R&D monies are investigations to determine whether the price of the premiums for insurance will be too high to pay. We may know the risks -- R&D defines the risks better, assigns the cost of counteracting them."

"Getting back to my first point," said Dr. Kirchner, "I still think that Captain Dudley's group should avail itself of its 20/20 hindsight when writing up reports for the record. My second point is simply that we have extreme disparity in opinions about the threats presented by the Russians. This, of itself, has a great effect on the use and value of the systems and of our assessment of our own capabilities."

"To get into another subject area," said Captain Dudley, "and one that I did not intend to bring to the Steering Task'Group, for about two months now I have been the Chairman of another committee which was formed to answer a letter from DDR&E, a task quite similar to

[REDACTED] COMMAND COMMUNICATIONS COMMITTEE DISCUSSION

what you are doing for POLARIS Communication. A working group was established consisting of myself as Chairman, Dr. Craven, Captain Barrett, and five different CNO members, to include all the various facets of CNO. We have both the communicators and the operators from OP-03 and 31, the national policy people in OP-06, and the research and development people in OP-07. We have been meeting about two or three times a week now for almost two months. We have come up with another sizeable report in which we go over word-by-word and item-by-item many of these systems developed for POLARIS Communications and put on the shelf.

"We have tried to delineate our thoughts on national policy and how it is tied in with the requirements for POLARIS Communications. As an end result, this working group developed a set of requirements that we feel are valid, relating to hardware. If this is ever approved, it might be something we can then hang our hat on. For example, this is the type of recommendation that we have tried to pin down: As a minimum objective, it is necessary for the SSB(N) to receive a total response strike message within 15 minutes of a national decision to strike. The SSB(N) should have this capability while maneuvering at depths of from 400 to 700 feet at 20 knots. It is desirable, and only desirable, for the national command authority to receive a brief message from the SSB(N) within 15 minutes after transmission with a low probability of the SSB(N) being detected, intercepted, or located by radio direction findings. It is neither necessary nor desirable for the SSB(N) to confirm launch orders. The communication data rate of the order of one-tenth to five-tenths of a bit per second is acceptable.

"One recommendation of the working group is given as an intention of the Navy, that the Navy should implement at a substantial cost the ELF system to meet our objectives or, should DDR&E not support this decision, to then implement VLF and the alternate systems.

"In other words, the basic recommendations for a transportable multiple dispersed VLF high-flying wire system made up of several NOMAD's, TACAMO's and so forth; this is what we commonly call the BAGATELLE mode. We said that the Navy should investigate how such a system would meet the Navy objectives and if it would cost more

than an ELF system of comparable dependability. By Navy objectives, I mean the ability to get a message through in 15 minutes to an SSB(N) at 400 to 700 feet and 20 knots.

"The recommendations have been worked out with the CNO people and we hope that they are selling them in their own house."

Mr. Peterson observed that a portion of Communications' 100 million dollars had been spent, if the facts are faced, in an attempt to formulate national policy and Navy intent, and that Captain Dudley's Working Group would not have been able to come up with a new set of recommendations if the Communications R&D money had not been spent. Dr. Kirchner added that the working group ought to have some document which represented CNO's overall outlook, as this would make their recommendations more meaningful.

"We will know CNO's position," explained Captain Dudley, "because our letter goes from Special Projects to the Assistant Secretary for R&D, Dr. Wakelin, via CNO; if CNO signs it, then he is agreeing to it. CNO may not sign it. He may not agree to it, or he may agree to it with enough reservations to make it invalid. We are attempting to get a clarified policy, an accepted requirement, or a statement of requirement for communications. We do not have one now."

"Technically we know what we can do. We know what it is going to cost. We know what capabilities it will provide us. We are giving CNO the picture; then they can choose."

"One point that needs consideration," said Captain Sanger, "is that some of the Communications programs could have been assayed without carrying them as far as they were carried. This may be a reflection of the PDP philosophy which suggests that things may be studied carefully before any big money is spent on them."

"Even so," answered Dr. Kirchner, "I think that the files could be fortified by the careful inclusion of all the fringe benefits attached to these efforts. It is hard to tell what future benefits might be sparked by these files."

[REDACTED] COMMAND COMMUNICATIONS COMMITTEE DISCUSSION

"The various CNO members," explained Captain Dudley when asked about the attitudes of the Working Group, "held divergent views. The operators from Op-03 and Op-94 were most helpful. The members from Op-07, which is CNO's R&D group, were unwilling to go into this effort without defining items and going into about two more years' worth of studies and analyses. They want to get a concise definition of the net military capability of each little facet of the system. Also, Op-07 did not agree with the basic recommendation while Op-94, Op-03, and Op-06 did agree."

NAVIGATION COMMITTEE REPORT DISCUSSION

"Program 435, which used to be called the TRANSIT satellite, has in orbit one fully operational satellite, number 5BN2, with a nuclear power supply," began Captain Gooding. "We have been taking fixes from this instrument on the USS COMPASS ISLAND and, of course, on submarines equipped to do so.

"On the last trip of the USS COMPASS ISLAND, 18 passes were received. From these, we got 15 fixes, of which 12 were good, or about two-thirds of the available passes delivered good fixes. The error in latitude and longitude as compared to LORAN C or LORAC was 0.35 latitude and 0.32 longitude in nautical miles.

"In the previous trips, there were 10 fixes from 16 passes, and 5 good fixes from that 10. The errors were 0.32 n.m. latitude and 0.34 n.m. longitude. We cannot detect a particular bias on the system. The RMS of four particularly good points on the last cruise gave latitude errors of 0.08 n.m. and longitude errors of 0.09 n.m.

"We have had a significant number of fixes with LORAC as a calibrator and they appear to be random also. They are no better or worse than the fixes, compared to LORAN, indicating that the randomness is from the satellite, or the program, or both.

"These numbers may not look remarkably good. Three-tenths of a mile is no longer considered remarkable in navigation. The SSB(N)-617 returned from her first patrol last week; she deployed from Charleston to the Mediterranean. En route she used the 435 satellite for position reference, and she arrived in the operating area with all the three SINS in specification.

"This is the first time we have been able to make that statement. In bad cases it takes anywhere from 18 hours to as long as three days

to settle out all three SINS after arrival in the operating area and to pick up position reference.

"A further development is that the Chief of Naval Materiel has directed SP to assume technical and financial control of Project 435. A plan for doing so has been sent to ONM. It has been there for some time, and they have been going to sign the approval letter for the past week.

"Two meetings ago, I showed some illustrations of a fine-grain bottom structure showing the analog monitoring of the E-array sonar. We did not take up the digital portion of the array sonar working; between then and now we got it working for about four hours and then it slid quietly into the bilge.

"As of this morning, we have had two very encouraging reports from the USS MICHELSON, the first of the survey ships so equipped. They report several days of reliable operation. It is a very complex system; indeed, it may be the first of its kind. The first one was on the USS COMPASS ISLAND, and that is not working either. The ship has been in overhaul for four months and if it has been debugged I am very pleased. Of course, as soon as the sonar array came off, the SINS went down and stayed down.

"The STG is possibly tired of hearing me talk about the superior performance of the SINS Mark 2 Mod 3 on the USS COMPASS ISLAND, but its performance is important and I am going to discuss it briefly from a different point of view. In figure 1 we have analyzed four separate uses in the USS COMPASS ISLAND, and you notice for the navigator an eight-hour figure of merit going from 20 percent to 50 percent specification and 40 percent to 50 percent specification latitude and longitude; the cumulative of all these 32 runs is about 30 to 40 percent specification. The azimuth numbers, 18 seconds and 16 seconds, for eight hours continuous monitoring are pretty good. However, partly because of the prodding I received from the STG in previous meetings, we have computed the 24-hour figure of merit. The numbers do not differ much from the eight-hour numbers. Twenty-four hours is a bad time to reset a SINS because you run the risk of reinforcing the natural 24-hour

NAVIGATION COMMITTEE DISCUSSION

disturbances. Twenty-five hours or 23 would be better, but whatever the reset interval, it is clear that after 8 hours the accuracy of TDP 2500 could be maintained for 24 hours. It is also clear that these accuracies could be maintained for 30 hours if the need arose.

"We do not have a 24-hour period for azimuth. You just do not get 24 hours straight of stars under normal conditions, so all we have is the 8-hour period."

"I do not understand why you can get it for 8 hours and not for 24 hours," remarked Dr. Kirchner.

COMPASS ISLAND PROGRAM

MK 2 MOD 3 SINS						
8 HOUR FOM						
TRIP	RUNS	TRIP		RUNS	CUMULATIVE FOM	
		LAT	LONG		LAT	LONG
1B - 64	7	0.10	0.23	7	0.10	0.23
3 - 64	10	0.09	0.19	17	0.09	0.21
5 - 64	6	0.24	0.23	23	0.15	0.22
7 - 64	9	0.14	0.19	32	0.15	0.21

24 HOUR FOM						
TRIP	RUNS	TRIP		RUNS	CUMULATIVE FOM	
		LAT	LONG		LAT	LONG
1B - 64	1	0.12	0.19	1	0.12	0.19
3 - 64	4	0.15	0.28	5	0.15	0.26
5 - 64	2	0.24	0.20	7	0.18	0.25
7 - 64	4	0.22	0.23	11	0.19	0.24

8 HOUR AZM FOM					
TRIP	RUNS	TRIP FOM	RUNS	CUMULATIVE FOM	
1B - 64	3	18	3	18	
7 - 64	6	15	9	16	

Figure 1

"Using the tracker," said Mr. Cestone, "we were amazed that we were able to get 16 hours with the star brilliance and the sky condition. At night we were able to do a better job than during the day, when our efforts depended on where we were shooting from, how close we were to the sun, and the magnitude of the star. To date, we have never been able to track more than 16 hours out of the 24."

"Those numbers are an RMS figure over that period," said Captain Sanger. "They are not the difference between the start of the period and the end of the period."

"Normally, the way it is done on patrol, with a discrete heading, is to fix with the Type 11. These are not discrete heading fixes," continued Captain Gooding. "This is continuous star tracking for an eight-hour or 16-hour period, so you can indeed RMS the numbers."

"We do not know how they could do this for 24 hours, but the specification on this number for that latitude is 40 to 43 seconds, and it is clear that if you maintained a 30-hour reset interval, you would meet the specification in azimuth, also. You will notice, if you compare latitude and azimuth, that the number has grown slightly, increasing the reset interval by a factor of three. I think that there is no question at all that this navigator can meet the 8-hour figure for 30 hours in all three coordinates."

"Do you have any ideas, Captain Gooding, as to how long the SINS might run and still stay within specifications; would this be 48 hours or several days, or what?" asked Dr. Barrow.

"Captain Gooding said, "We reset every 24 hours as a matter of routine. A1 and A2 Navigators on patrol have alleged they stayed in specification for 48 and 60 hours. I do not believe them. Their log book said they stayed in Red Book specification, because they have continuous LORAN C. We do not know what has happened to the azimuth, so we have no means of knowing whether they are in specification. They may be in specification in position and quite badly off in azimuth. Furthermore, we have found out the hard way that delaying the reset



NAVIGATION COMMITTEE DISCUSSION

interval deliberately like making it 24 or 30 hours -- in one case I think there were 60-some hours between reset on a particular SINS -- the worse the reset is; the information is poor and when the instrument is revised, you find out that you have not done it right.

"You are therefore prejudicing the long term accuracy of the system by letting it run longer than it is supposed to run. Now, this is only with the A1 and A2 SINS. We do not have that kind of experience with the Mark 2 Mod 3, but I would suspect you could run a couple of days and still stay within specification, assuming that you have good position reference data, a good operator, and the resets are put in properly."

"Returning to Project 435," said Dr. Barrow, "one of the things that bothered me earlier was the effect of the high altitude burst on the operation of the satellite. Does the new power supply improve this sufficiently to change the situation, or are there other things in it so that it still could be demobilized by such an operation?"

"It could still be demobilized by such an operation if you wanted to go to the trouble," replied Captain Gooding. "It does improve it. The satellites which are going to be launched in the future have additional solar cells for redundancy, so their life will be increased. However, any of them can be demobilized by putting an intensive enough field up there. There is no practical way of absolutely preventing a radiation field from killing these things."

Mr. Stevenson asked what were the azimuth possibilities with the 435 satellite. Captain Gooding replied that there were azimuth possibilities, but something in the submarine comparable to the radiometric sextant would be needed to get azimuth from the satellite. He said a very high frequency transmitter -- 8 to 32 kilomegacycles -- might be needed.

"As the STG knows," continued Captain Gooding, "a radiometric sextant was installed and operating very nicely in the SSB(N) 610. On a recent patrol, a loud thumping noise came from the conning tower.

What apparently happened was that an oil-bearing aerosol was free in the dome, which is pressurized by air. It was ignited, probably by a heater circuit, and the detonation blew off the plastic dome and sprung the door to the pressure-tight locker which holds the dome. The antenna was completely demolished.

"The pressure door has now been welded shut, and the electronics in the ship either have been or will be removed, so the RMS is no longer a part of the system at all. SP has stated to CNO that the requirement for the radiometric sextant does not exist; we have recommended its removal from the Ship's Characteristics, and that has been done."

"We made a recommendation about the azimuth capability of 435," said Mr. Morton. "Since the monitoring gyro system appeared to be progressing very well, the complexity of trying to put an azimuth capability into a satellite system was not warranted."

"The basic point is that if a position is good enough, the monitor will give an excellent azimuth," interjected Mr. Forter. "The two tie directly together, so with extremely good position you will get extremely good azimuth with the monitor."

Lt. Commander Magee (Representing CINCLANT) then gave the results of the USS HAMILTON (SSB(N) 617) patrol. The USS HAMILTON had 120 fixes which she did once every 12 hours while in the Mediterranean on patrol. They had 79 successes and 41 failures. The success criteria was 0.3 n.m. for both latitude and longitude. Of the 41 failures, eleven were technical and 35 were caused by wave quenching. The antenna is three and one-half inches in diameter and 48 inches long. They had problems with sea states because the pole has to stay up for 8 and 16 minutes per fix.

"It is up to the Captain to decide how long to keep that pole up, as this means staying near the surface. However, they believe that with their depth control they can get accurate fixes with just one satellite.

NAVIGATION COMMITTEE DISCUSSION

"When you consider that the system will not be fully operational until four satellites are up, this is a very successful way of navigating.

"Basically, Sea State 4 gave us the wave quenching problem with this antenna."

"The Mark 2 computer programs which are scheduled to be delivered on 5 November will either eliminate or minimize this quench problem," said Captain Gooding.

"In fact," remarked Mr. Morton, "the one in between the Soroban electric system was a big improvement over the present program. It is a matter of synchronizing the data, and you must keep six minutes of continuous data coming in. This program is available for the 627, but also usable on the 616 Class, so the next patrol ought to have this kind of data system."

"The Chairman asked each of the STG Committees to have the subsystem contractor manager present a brief updating of the logistic presentations you heard two months ago," resumed Captain Gooding. "I requested, and got, his permission to present it myself rather than dumping a load on Sperry and Autonetics, partly because it is my responsibility and it is just barely possible I might learn something.

"I have back-up in the audience just in case your questions get too searching. You will observe in the figures that follow some progress, but also a new problem. I do not believe that the recent interest of the STG in logistics is responsible for the progress, nor is it responsible for the new problem.

"Figure 2 is the Mark 2 SINS spares workload to date, with 65,000 spares ordered, and some 63,000 delivered. In the past two months about 2,000 more pieces have been delivered, and right now some 2,000 are yet to go. By no means are all of these delinquent, of course.

**MK 2 SINS SPARES WORKLOAD  
(DOES NOT INCLUDE MISC SPARES CONTRACTS)**

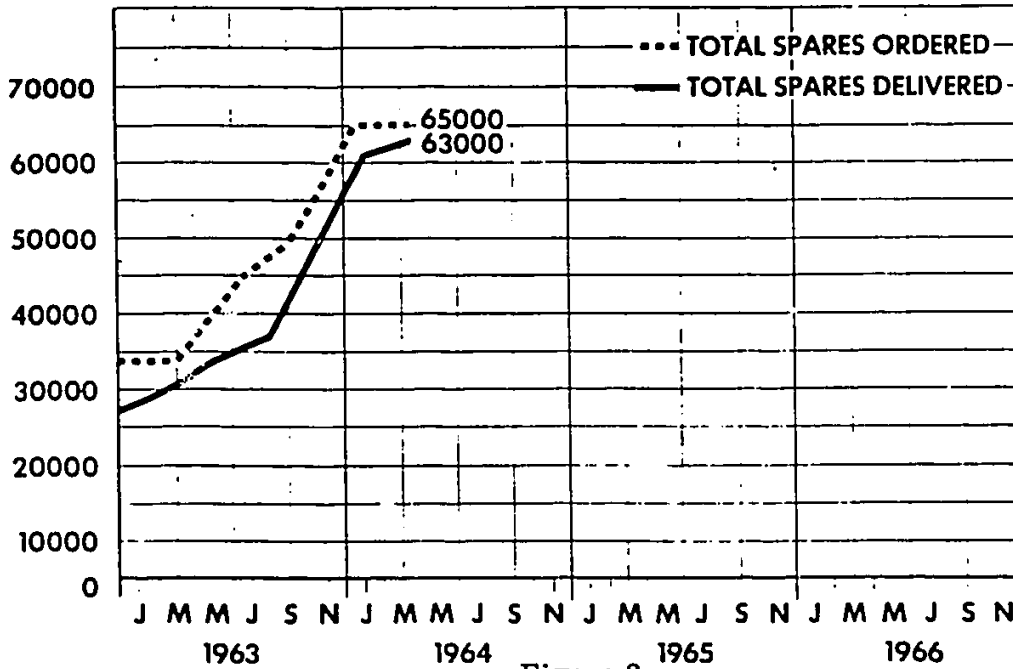

Figure 2

"The delinquency in Mark 2 SINS spares is shown in figure 3. The line item is the solid line. The dotted line is the pieces still out. The delinquency is now down to about 500, an improvement of about 600 since we last met.

"The repair workload is depicted in figure 4. The first peak was the USS PROTEUS offload. The second peak was due to an unfortunate situation when there was no repair contract. You notice that the area under the solid line, which is the received curve, appears to be greater than the area under the dotted line, which is the shipped curve indicating the backlog.

"It seems to me that the disparity between those two areas is rather large, and maybe I have a problem that I am not aware of. I hope not.

[REDACTED]

RE-ENTRY BODY COMMITTEE  
REPORT DISCUSSION

"The first item of my report today," began Commander Julian, "is the general status of the United Kingdom's re-entry system, figure 1. At the end of April, we received their decision to use the Mark 2 Mod 0 system in the front end of their A3 missile — at least it will be a Mark 2 Mod 0 in the sense that it will look exactly like our Mark 2 system. The UK will design and fabricate the Fire Set and the nuclear system — these are items that the AEC makes for us — but otherwise they will buy from us all the other parts of the system that they can. As a matter of fact, they could, if they wished, even buy the Fire Set from us, but they have decided to make it themselves.

UK POLARIS RE-ENTRY SYSTEM STATUS

DECISION TO INCORPORATE MK 2 MOD 0 SYSTEM NOW --  
UK FIRE SET AND NUCLEAR DESIGN

UNDERTAKE UK PENETRATION STUDY -- RAE, MOA, MOD  
REPORT 1 AUGUST 1964

R & D HARDWARE ORDER IN HOUSE  
NEEDS SCHEDULING AND FUNDING  
PRESENT SD - HARDWARE ONLY - EXPIRES 31 DECEMBER

STATUTORY DETERMINATION FOR TECHNICAL SERVICES  
REQUIRED AS CONCOMITANT TO HARDWARE SALES  
REQUIRED FOR US AGENCIES TO ASSIST IN TECHNICAL  
SUPPORT  
REQUIRED FOR BEYOND PERIOD OF 1958 AGREEMENT

PRODUCTION ORDER NOW IN PREPARATION

Figure 1

"They also decided, as an independent part of the April decision, to engage in a short-term but intensive study of the penetration problem. Their objective is to determine whether or not the UK POLARIS system will need penetration aids. The report of this study is due out on 1 August and the investigating group will be chaired by RAE with participation by the Admiralty, the Ministry of Aviation and by MOD of the Admiralty. While we are not involved in this study at all, I suspect that their report will be 'Yes, the UK does need penetration aids.' If that is their recommendation, then the penetration aids will be developed in a form that can be retrofitted onto the submarines already constructed, as it does not seem possible that they can solve the PX problem soon enough to equip their submarines sequentially.

"It is quite possible that we in the US will be asked to help engineer the penetration system if they decide that they want one, and I feel that both the Navy and the contractors will be ready for any assistance they may be called upon to give.

"We have the order for the on-hand R&D hardware which, while it is a fairly small order, contains all the elements they intend to buy for their re-entry system, including both AEC and DOD components. They would like about 10 or 11 AFD's, about 10 complete flare assemblies, 3 or 4 base frame assemblies, and about 10 bonded shell assemblies. They also want the associated handling and test gear.

"They desire these items so that they can go ahead with the development of their own handling and assembly gear and fixture, if they feel that the things they develop would be more adaptable to their way of operating. It is quite important with the AFD's and all parts of the system involving mechanical and electrical interfaces that their fire set, which they are committed to design, be compatible with our system, and that the system they finally go to sea with will be able to satisfy all the environmental conditions.

"For our part, we cannot satisfy this R&D order until we get more information from the UK. I feel quite certain that they will wish to receive one of each item immediately; it does not seem possible that we will be able to deliver one of each item to them before September. We have asked them to send us a general schedule indicating when they wish the first item and on what schedule they would like the subsequent items.

"We have a funding problem here in that the largest part of this front-end order involves purchasing under the 1958 AEC agreement rather than under the POLARIS Sales Agreement. We have agreed with the AEC about doing it this way, and the AEC will accept a single order for all parts to be sold under this agreement. They will then pass an interdepartmental request, together with an order and a schedule, to fill any portion of the initial order that calls for DOD source parts.

"The AEC is not happy with the way the order is written. They are picking at a number of small items here. For example, neither the AEC nor the DOD parts procurement make up a complete set of everything that is needed to put together one of these front ends. This is a shortcoming in the UK order, and we have been helping them by filling out their list by nomenclatures, part numbers, tool lists, and so forth. But we do have to wait until we get the money from the AEC before we can move to fill the order.

"We have another, more serious, problem. The 1958 agreement, under which this purchase is being made, requires the explicit permission of the President to sell this hardware. Special Projects has such explicit permission today to sell them all the hardware they want, but this permission expires on the 31st of August. We shall soon need a new permission from the President for further arrangements with the UK.

"The present agreement, and its special permission, do not cover the procurement of technical services which the UK will definitely need right along with the production orders for a long

time to come. These services will include training, assistance in formulating compatibility test plans, and similar things. We cannot give them these services until we have a renegotiation of our present working agreement.

"We have been working with AEC and with the MOD representative plus the UK people within SP to develop a format that we can use in procuring the kinds of services that we think the UK will need during the development and operational use of their version of the POLARIS system. We have gotten our joint thoughts down onto a working paper which is now seeing circulation among the UK Home Forces and among our OpNav personnel. Once we have commonly agreed upon the contents, we will implement the paper and then return to AEC with a new order, based on this paper, for items of hardware plus certain specified services.

"Then AEC will have to reach an agreement with DOD, through the Assistant Secretary of Defense for Atomic Energy, that such a statutory determination is again in the best interests of the United States and so on. This will take at least two months. Thus we foresee an appreciable time before we can supply the UK's needs for both hardware and services.

"There is one foreseeable perturbation here, in that the need for these services will extend into the period of operational use for the UK system — 1970 and beyond. This time span is well beyond the viability period of the 1958 agreement. We can do nothing about this; the two governments will have to negotiate an extension or a new agreement by 1969.

"As a final note on the UK matters, they are now processing their production order, which will be the large order for all the equipment and hardware they will need for their five submarines. We expect to have the order in this country within a few months.



"Figure 2 illustrates the source of a rash of difficulties — some large and some small — associated with the transition to production from development of the Mk 2 Arming and Fuzing Device. I picked out here one of the more serious of the problems which was uncovered in three tests. This incident showed up in a test at the AEC Medina facility at San Antonio in their survey of a unit which they call "new material sample." The item tested was one of the first warhead systems built and contained one of our first AFD's. During the test it was noted that, when the proper electrical inputs were applied, the decelerometer failed to unlock. If the decelerometer fails to unlock in flight, the

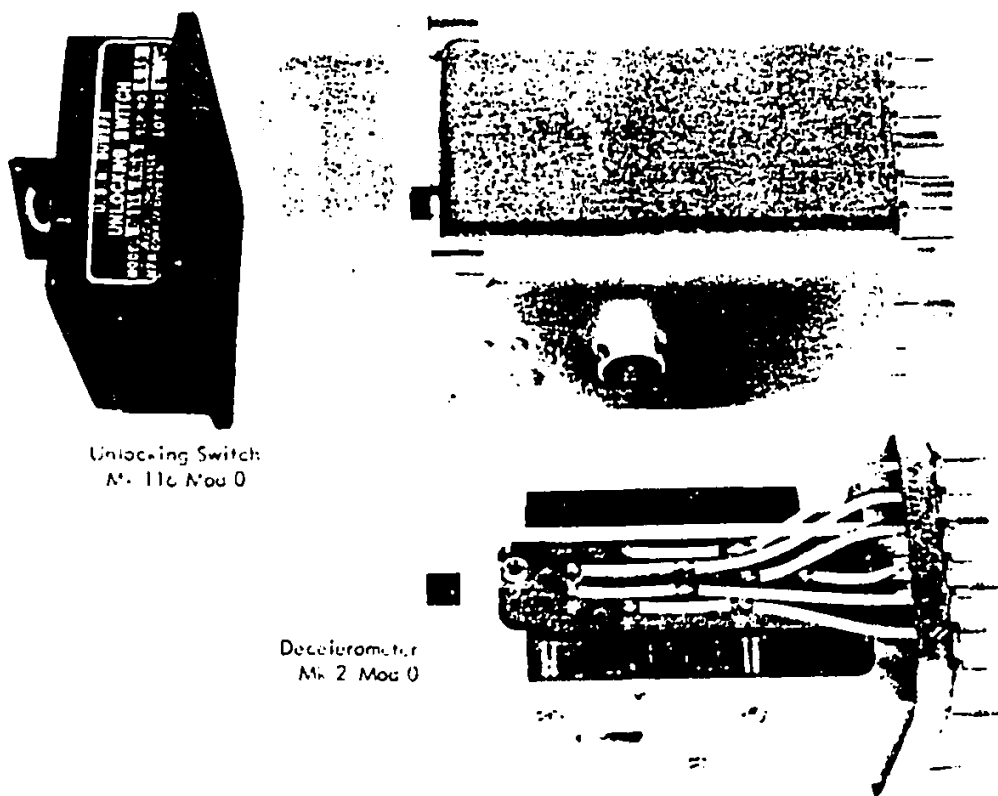

Figure 2

system is irrevocably dudded. We also learned that one at AVCO failed and one at NEL failed to unlock. We immediately withdrew decelerometer certification of all AFD's that had been delivered and began the witchhunt to locate the difficulty. "The shaft is operated by the switch, which is apparent in the picture. On the same shaft you can see the flag through the optical window in the back of the warhead cover. The flag indicates that it is safe-locked, or ready-unlocked.

"Figure 3 is an enlargement showing the switch and the flag. You can see a little paddle which is directly coupled to that switch and sits here in the unfired position. With this, there are two small explosive bellows motors. On receiving the proper electrical signal, both bellows motors are fired; then the expanding bellows moves the paddle around to shear a pin in a slot. From there it continues to move against the low-resistant torque of that jamming surface to turn the shaft and take two detents out of the decelerometer, thereby unlocking it.

"In the units that failed, we found among other things the facing surface was a rough sand cast and unfinished, and also that the bellows extensions were distorted. While they were being bent by frictional force, the paddle just hadn't moved far enough.

"There was also a problem of length control in that little pin. Some pins were so long that there was residual metal left when this thing actually sheared. The pin didn't shear cleanly and a high torque was needed to move the system around.

"Figure 4 gives the torque characteristics of the old system and the new and the two bellows motors. There was a 0.145-inch gap between the surface of the paddle and the little button at the end of the bellows, and a single motor was used. The figure defines the torque requirements first to shear the pin which has a precise, close-fit hole on one side and on the other a large hole. The first movement shears the close-fit side and it moves a little. After shearing, there

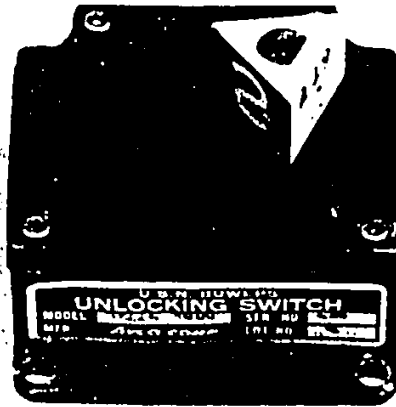

UNLOCKING SWITCH  
MARK-116 MOD-0

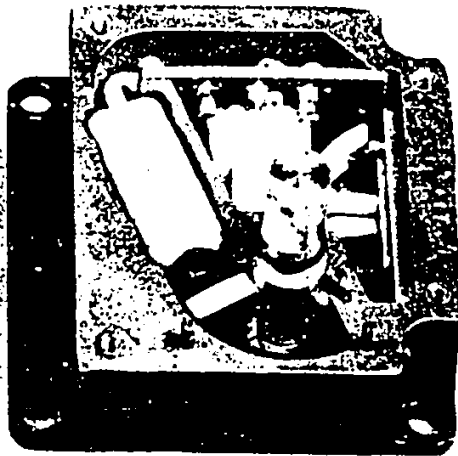

FIRED

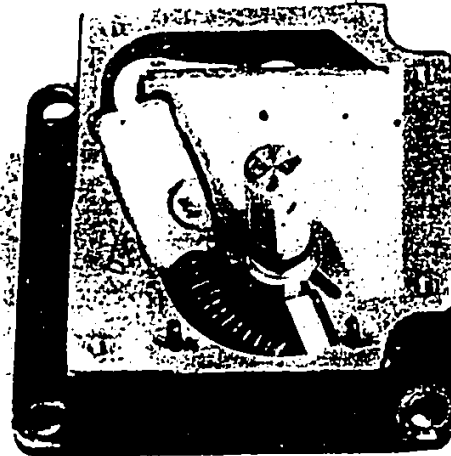

UNFIRED

Figure 3

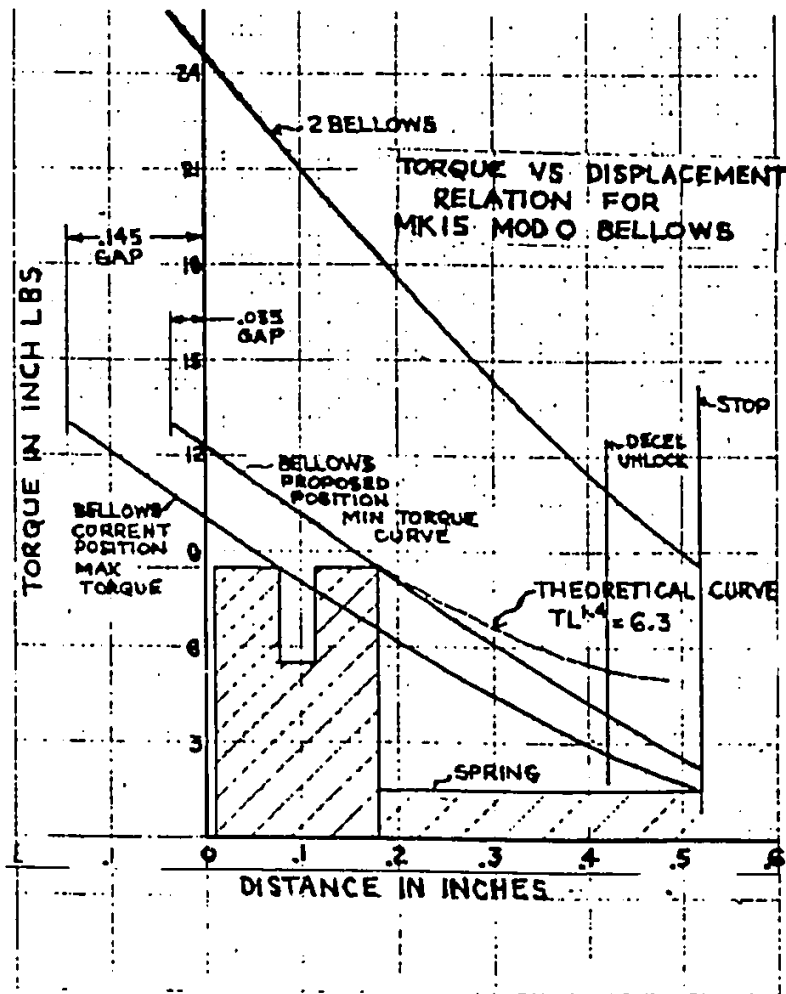

Figure 4

is still torque that must be used to shear the other side of the pin. Those are the torque requirements to which must be added the residual drag or torque of the carrying surface. And you can see, with this amount of free pre-run of the bellows button, one motor could not operate to shear both sides of the pin.

"We have done several things to improve this. We have machined and moly-coated the camming system. We have decreased this gap, and we have tightened up considerably the process control

on the length of the pin. Now this represents test results of about 60 units, 25 of which were fired with a single bellows motor and not two — all of which worked satisfactorily.

"With this reduced gap, one motor alone has enough force to operate the paddle to complete unlock. With two we have a fat margin of safety. We feel that the problem is licked, and we began on the 11th of this month to deliver recertified and reworked AFD's to the AEC.

"Figure 5 is the recovery schedule. The capacity at AVCO and at Dam Neck is considerably beyond our requirements as represented by the triangular keyed line, although some numbers are a little bit in error. In this fiscal year, AEC is required to deliver 57 units.

SCHEDULE RECOVERY

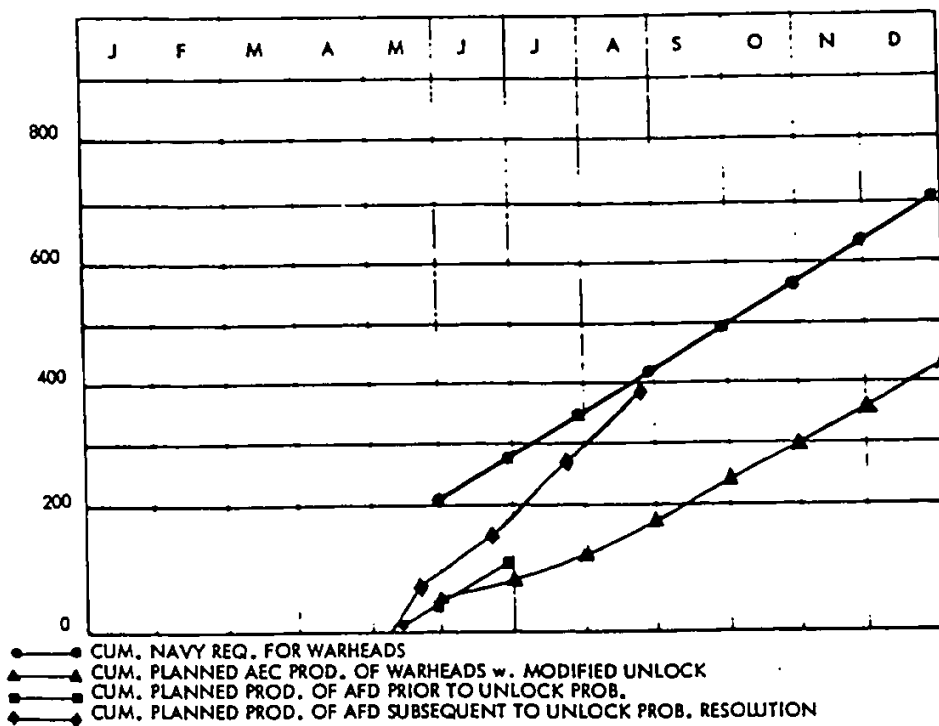

Figure 5

"As you can see, the planned deliveries of the AFD's and our present situation regarding AFD's leave us well ahead of what AEC requires. AEC has stated that if we recover to the planned delivery schedule, then AEC can most likely better their requirement schedule. Most important, we have not set AEC back because of this problem nor placed them in a position where they cannot meet our warhead requirements.

"We have at least one more problem requiring final resolution and we are in the process now of looking very closely at all of the inspection and acceptance specifications and requirements that were put on AVCO. We also have a plan for further validating the evaluation program, by the steps shown in figure 6.

#### VALIDATION OF THE EVALUATION PROGRAM

1. ACCELERATE FORMAL EVALUATION PROGRAM.
2. IDENTIFY DIFFERENCES BETWEEN PRODUCTION HARDWARE AND EVALUATION HARDWARE. DETERMINE THAT CHANGES HAVE BEEN ADEQUATELY EVALUATED BY TEST OR BY ENGINEERING JUDGEMENT.
3. RESOLVE EXISTING PROBLEM AREAS IN MEETING O. S. REQUIREMENTS BY RELAXING REQUIREMENTS IF JUSTIFIED OR BY IMPROVING MATERIAL TO MEET THE EXISTING REQUIREMENTS.
4. EXAMINE PRODUCER PROCESSES AND TECHNIQUES TO ASSESS THEIR ADEQUACY.
5. PROVIDE TO SPO INFORMATION AND RECOMMENDATIONS REGARDING THE ADEQUACY OF THE SUPPLIERS AND ITS RELATIONSHIP TO POLARIS RELIABILITY.

Figure 6

"In the evaluation program conducted by NOL, they withdrew 75 of the first production units, and ran them through all the environmental and functional tests. Now it appears that the validating sample

was neither homogeneous nor representative of the production lots. Because of the changes we are going to make, the evaluation lot will not be identical to the production units. There is a definite possibility that some change occasioned by our difficulties will in some way invalidate the validation. Thus, we must rapidly evaluate the remainder of the validation. Our evaluation program has only about two more months to run, and this acceleration means that we must get this one remaining problem resolved in a hurry.

"The basic trouble has to do with the threshold for the decelerometer sensing, where some variations have shown up. We think that by taking the process at AVCO, this can be solved.

"We are definitely going to identify between the production lot after all of these changes are in and the evaluation samples. Nor are we going to be content with this evaluation sample. We plan to withdraw a periodic production test lot at regular intervals, and using these test lots, we intend for a long time to confirm that the production is in fact what we want it to be and is identical with the documentation. The figure defines five areas that we are going to explore."

Lt. Commander Magee asked about the effect of the AFD changes on the reliability of the warhead. Commander Julian explained that the AFD was certified by the Navy rather than by AEC and that it has the reliability planned for it - and that the overall warhead reliability will not be affected and will remain at

"It would take a completely new evaluation program," continued Commander Julian, "to change those figures, and we will not have enough samples for such a program within five years. I feel content that the design is adequate for the changes and will not be degraded by them.

"The Mark 12 Vehicle, shown in figure 7, is moving ahead somewhat slowly, although in one major sense it is also foundering simply because AEC does not as yet have any formal detailed design criteria in the area of military characteristics.



Figure With-held

CRD

"Now, there is some promise in that today DASA's characteristics were finally coordinated and that Air Force, Navy, and DASA agreed on the words and format. This document will be forwarded to the military leaders on the committee passing on the requirement. Even so, there is a glitch. The document has to be reviewed and approved at DDR&E, and this Friday these people; including Fred Payne, are going to talk to Secretary Flax of the Air Force. They will ask why the Air Force has included in the military characteristics a change in the yield stipulation; they may ask if Air Force is not trying to change words in the military characteristics to get a little more guarantee that the yield will be limited absolutely to a minimum of \_\_\_\_\_ This change would increase the weight of that body to more than the previously acceptable maximum of \_\_\_\_\_ We can now take \_\_\_\_\_ and still put six aboard the B3 and get 2,000 miles without breaching the contingencies for first or second stage. If the weight goes beyond 365

CFRI





comparator or the DA intelligence converter, are in the fire control. This system requires modification in the fire control. The missile then will need only a switching device to switch from one black box to another and set the switch sequentially.

"Still another variation to be discussed next week is a system in which, if we modify the way that the G-second intelligence is set into the I-A, we can then make a direct setting from fire control into our fuze. I say 'our fuze' because this technique would mean a Navy model of the Mark 12 with our own AFD. Should we do this, then the Air Force would certainly suggest a lot of other changes that would soon make our model quite different from theirs. I do not think this would be too acceptable, because the basic idea is not to develop two totally different systems. Next week we will discuss all the various technical and political implications of putting in that type of fuze.

"There are other variations that would make the Navy B3 and A3 prime interface and configuration job much simpler than does this fuze but they suffer from certain deficiencies. For example, we could greatly simplify things by putting in there a radiating fuze, one that is merely turned on to wait quiescently until it senses a certain altitude above the ground before it goes off. These fuzes are available for development, but they are remarkably susceptible to countermeasures.

"Another kind is one we proposed earlier — a straight timer fuze. It relies on something like .01G to start and then times on from that point forward to fuzing altitude. That is quite sensitive to variations in trajectory and probably with the time-only fuze you would have to by-pass a lot of the environmental sensing safety that we now have, so that has its disadvantages too.

"We are investigating all of them and hope to find the interface very soon. Next week we will discuss three: one, the interface box in the middle, two the major fire control change to permit setting of this system with one I-A or DT preset, and three, the direct setting system."



In answer to questions from the members, Commander Julian explained that the flag indicated a safe condition only in that battery actuation was prevented until after events had occurred to wipe out the flag indication.

"Lately, we have been looking at a problem with the SUBROC," resumed Commander Julian, "although we do not think we are going to be troubled by it. SUBROC uses substantially the same kind of warhead as we do in the Mark 2 in that both warheads use [REDACTED] in the [REDACTED] Thorium-232 is radioactive itself, and will, after  $10^9$  years, gives up an Alpha particle to become radium. There is a plan to store the SUBROC missiles under the deck plane of a berthing compartment; this places the warhead within 18 inches of the person sleeping in the berthing area. Figure 9 shows the decay of thorium 232; one point of concern is the very high gamma with thallium 208 — it is 2.63 million electron volts gamma rate — and this will require about six inches of a composite lead and poly-shielding around the storage compartment for the SUBROC installations. CRD

"We checked to determine what this gamma rate would do in our system and the fields are shown in figure 10. Considering that the acceptable industrial tolerance is 5 rem per year assuming 40 hours of exposure for 50 weeks of the year, we are in no trouble at all on the submarine. However, we may have a problem at NWA with the people who actually work on the re-entry bodies, as they can easily accumulate large dosages of gamma rays on the hands, wrists and forearms in particular. Again, these would not be excessive doses necessarily, but they would be a lot larger than we are normally exposed to. We also may see a problem when we store a number of these warheads on the bare bulkhead on the tender, which we were planning to do.

"Because we do not know whether we have a problem or not, nor do we know the size of the problem if indeed we have one, we have asked AEC to run some measurements for us at NWA of both the neutron and gamma fields in the working area and around the



CRD

Figure. With-held

front end of a cluster. We also wish them to measure a bare warhead at PANTEX for a determination of its fields.

"I feel sure we have no problem with the missile in the launching tube, but to make certain of this we have also asked AEC to make some measurements from which we can extrapolate the circumstances on the submarine. I believe AEC will set up an array of nine and measure the fields around the array. These will be somewhat unrealistic conditions, and I think the extrapolations may also be unrealistic because of the unmeasured scattering effects. To give ourselves a complete dossier on this problem, the AEC has also agreed to make an array measurement aboard the USS PROTEUS when she returns for shipyard availability this summer. We would like them to measure the compartment completely with from six to



## TYPICAL PATTERNS

TYPICAL  
STORAGE  
ARRAY  
(FBM TENDER)

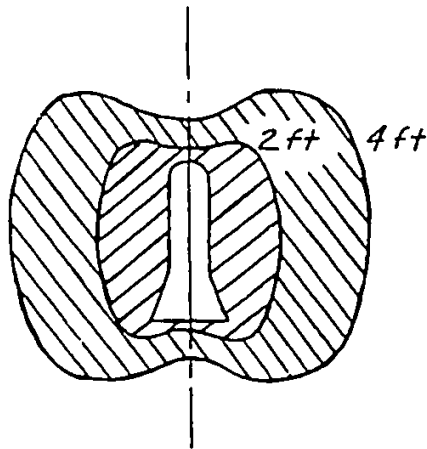
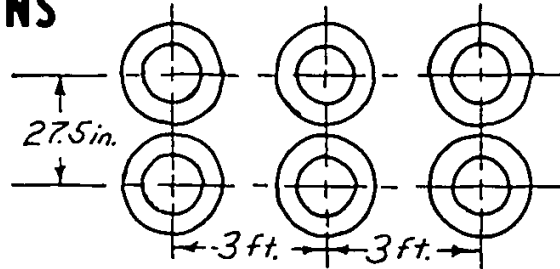

POLARIS  
MK 2 MOD 0  
SINGLE BODY  
ISO DOSAGE PATTERN  
(ESTIMATED)

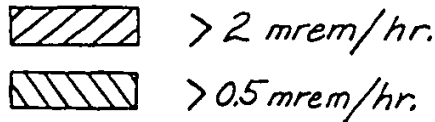

Figure 10

nine warheads in it, bare on the bulkhead, and to extrapolate from these measurements to the configurations of AS-31 and AS-32. I doubt if the dosage rates will be high enough to warrant additional measurements.

"We have been aided in this by Dr. Shuly of BUMED, who has been responsible for measuring personnel exposure to all radiation. We are setting up a dosimetric badging procedure at BUMED where all handling personnel at NWA will wear badges at all times when exposed in any proximity to the Mark 2 system. The people in the REB shop will probably wear either wrist or finger badges. I do not think that, in a year's time, any of these people will exceed the industrial tolerances, judging from the numbers we have seen, but



the evaluation of the records will show whether or not we have a problem.

"The tolerance standards, figure 11, are quite involved. If we find in our measurements on shipboard and at NWA that the maximum anticipated dosage is less than 0.5 per year, we do not have to do anything, or if the radiation level is less than 0.002 rem in any one hour or less than 0.1 rem total for any one of seven consecutive days. We need not do anything. We do not even need to mark the space or identify it, as it is an unrestricted area.

"If we find the dose rates on the ship are such that the maximum exposure would be 1.25 rem per calendar quarter for a whole body, or 18.75 rem for limbs per calendar quarter for the shop people, then we must identify the area as a restricted area. No further restrictions are necessary except that we must caution people not to loiter there and badge them.

"The formula can be useful in that the five rem-per-year is based on the working expectancy of an individual who starts work at age 18. So if we have shop people at age 20 or older, then we take advantage of this. Hence I do not think we have a problem; we shall make some measurements to see what the extent of it is, and for the present, we shall badge the people who are exposed to it. BU MED will carefully look at the records and, after a year or two, if the situation warrants it, we will cease badging."

Mr. Peterson wished to know if the SUBROC was ever going to be planned again for SSB(N) installation and, if it were, what the lead shielding would do to the marginal lead. Captain Sanger replied that SUBROC's future on SSB(N)s was completely indefinite; Commander Julian added that the shielding came at somewhat more than 60 pounds per square foot, but Dr. Mechlin observed that the berthing arrangements were not the same. Commander Julian agreed that the exposure problem would be eliminated by removing one row of bunks.



RADIATION DOSAGE RESTRICTIONS  
(title 10, U.S. code)

- I. UNRESTRICTED AREAS - BERTHING, MESSING, OFFICE SPACES)
  - A. MAXIMUM DOSAGE LIKELY - LESS THAN  
0.5 REM/YEAR
  - OR B. LEVEL OF RADIATION - - LESS THAN 0.002 REM IN ANY ONE  
HOUR OR LESS THAN 0.1 REM TOTAL FOR ANY SEVEN  
CONSECUTIVE DAYS.
- II. RESTRICTED AREAS - (DESIGNATED SHOP AND MAGAZINE SPACES)
  - A. MAXIMUM EXPOSURE - 1.25 REMS/CALENDAR QUARTER  
(WHOLE BODY)  
18.75 REMS/CALENDAR QUARTER  
(LIMBS)
  - B. MAY EXCEED (A), IF --
    - 1. MAXIMUM WHOLE BODY DOSE - LESS THAN 3 REMS/  
CALENDAR QUARTER
    - AND 2. TOTAL ACCUMULATED DOSAGE - LESS THAN  
3 (N-18)

WHERE N = INDIVIDUAL'S AGE

Figure 11

"On the A3X-53," resumed Commander Julian, "we had interesting results. The A3X-53 was the first of our PMR shots with PX as a primary objective. It was fired from the vicinity of Johnston into Kwajalein; and I have in figure 12 an intensely modulated plot from the data taken by the discrimination radar associated with the Nike-Zeus. This is the first time that the DR radar has been operating with a re-entry vehicle into Kwajalein. It is interesting data, particularly that part of it on the left of the figure. The reference line is 212,000 feet and from about 300,000 feet. We could follow the second stage destruct within a second, after re-entry body separation. From there, the second stage moves in pieces and is, I think the reason for the slowdown of the particles.



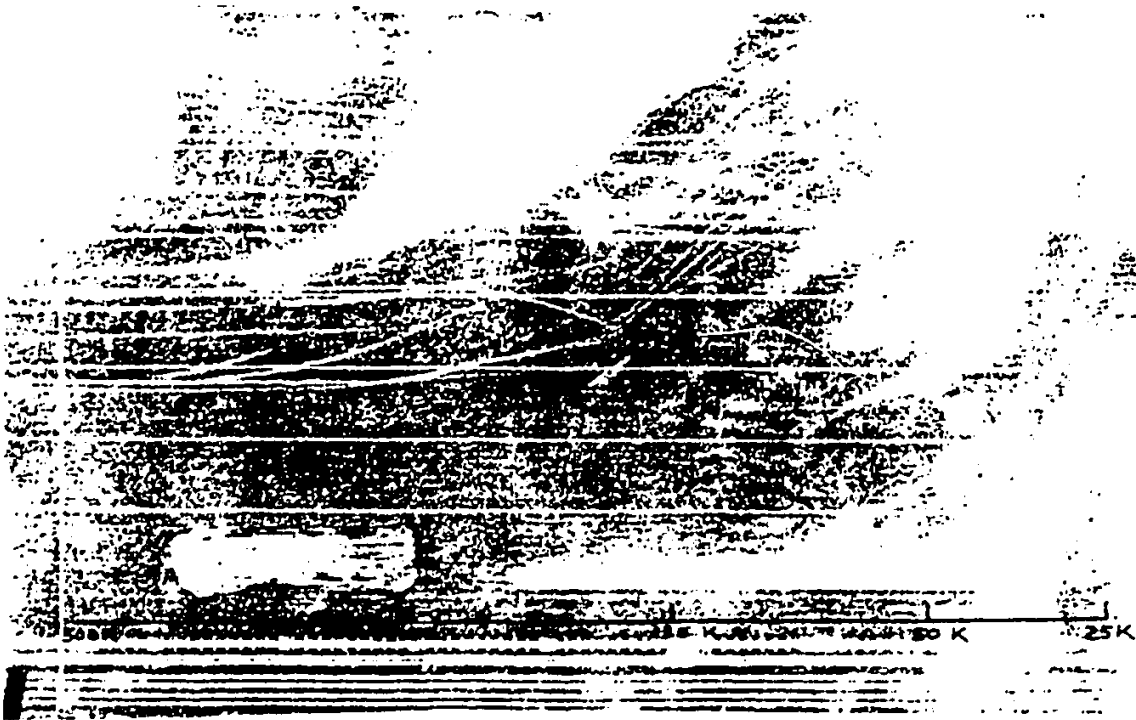

Figure 12

"The coordinates are range and altitude or time of flight, with time reading low to high. "

Anticipating questions, Commander Julian identified the range gate, the second stage, the decoys, the REB's, and the cluster; he admitted that some personnel claimed the ability to identify the various items, but that he could not do so himself until the missile got down to a fairly low altitude.

"Somewhere between 100,000 and 200,000 feet, " continued Commander Julian, "we saw evidence of a very intense wake on the re-entry vehicles; this wake is something that we most assuredly did not expect to see.

"We have since researched other data from the other flight, particularly A3X-48, and the DAMP observations from A3X-48, for more evidence on the wake.

"The wake length here is roughly 2,500 to 3,000 feet. I do not know what the equivalent cross section of that is. You cannot really tell from this film because it has been developed in such a way that the intensity per unit length is identical throughout — I do not think the cross section is that much bigger.

"There is no chaff in here, as this was a bare system without chaff and with six dark type decoys and with the three re-entry vehicles.

"We were quite surprised as was the Air Force; in fact no one would predict that at this re-entry velocity, at about 14,000 feet per second, would have developed the wake. We tried to make some correlation, and went back to look at the A3X-48.

"Figures 13 and 14 are some range-tracking pictures from the TTR, where you can see the ramp of the vehicle. You can also see the wake starting to develop here and become fully developed until the wake extension is about 2,000 feet. As a matter of fact, the length from the initial ramp of the body is better than 2,000 feet.

"Figure 14 gives the data from A3X-48 which we researched and found this interesting signature. This print-out is more like a positive print. You can identify the body at an altitude of about 130,000 feet, and also see the modulated signature which we now believe to be wake as the body oscillates. We have tried to correlate the body aerodynamic frequencies and this observed wake frequency; we find that the two are highly correlatable.

"Figure 15 indicates that the intensity and the length of wake appear to be a function of the angle of attack, or the plasma length in feet as a function of the resultant angle of attack. This data is taken from the plot I just showed you for A3X-48."



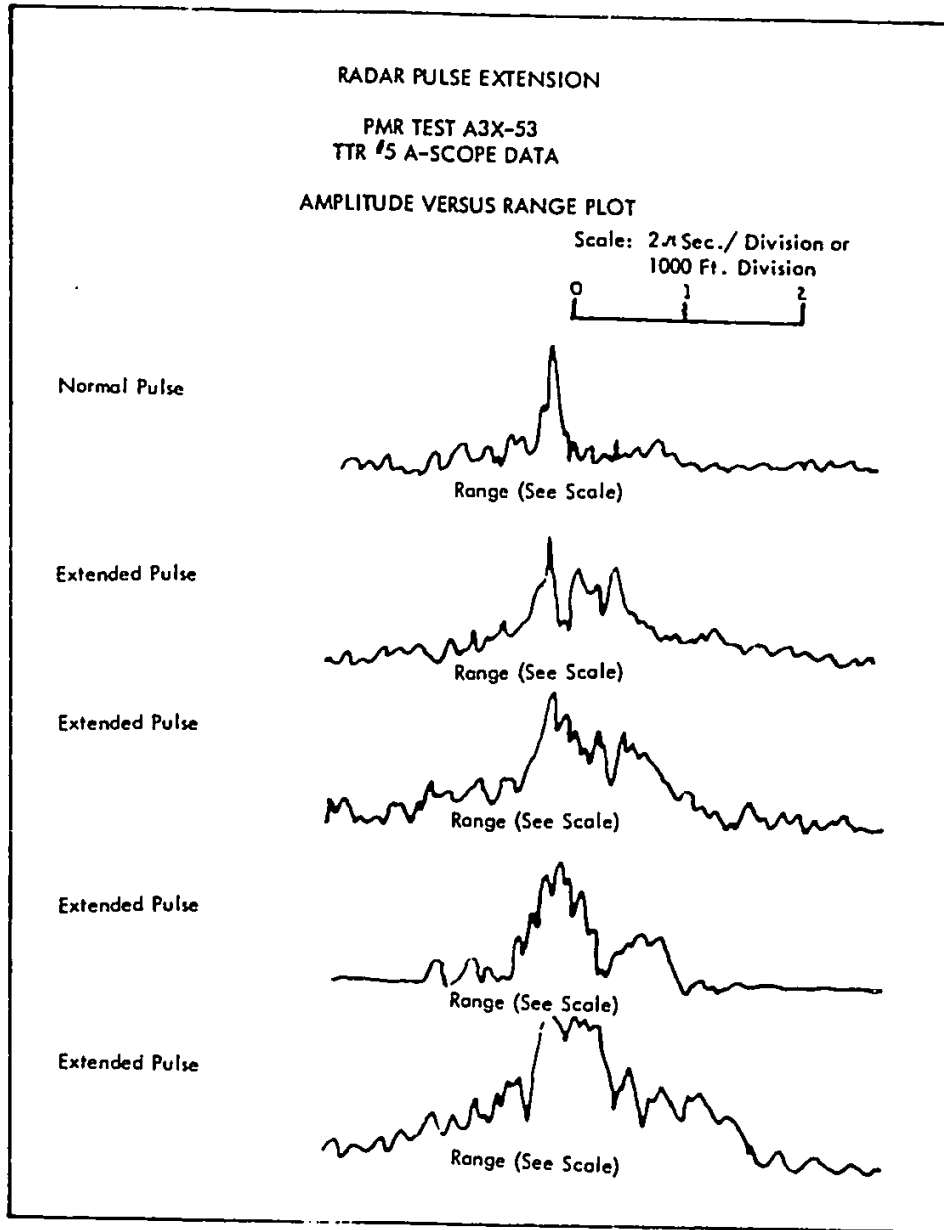

Figure 13

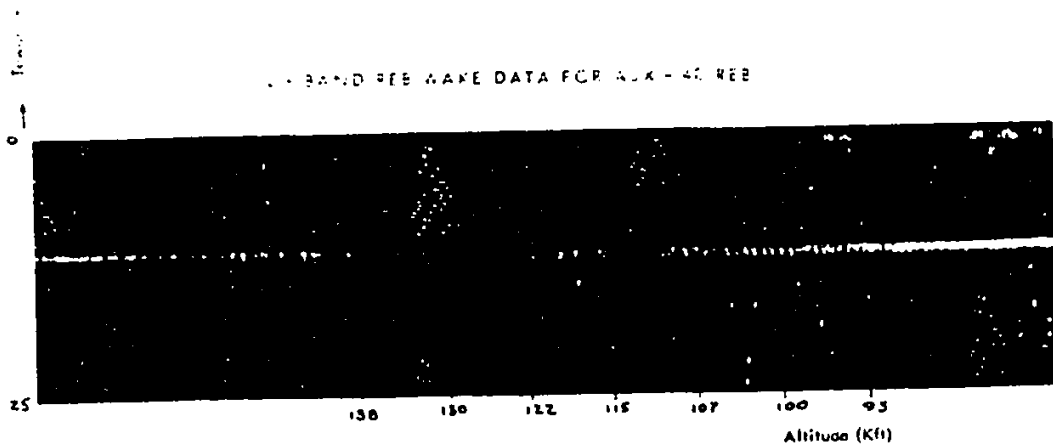

Figure 14

PLASMA LENGTH VS. ANGLE OF ATTACK FOR REB C OF THE POLARIS A3X-48 MISSILE

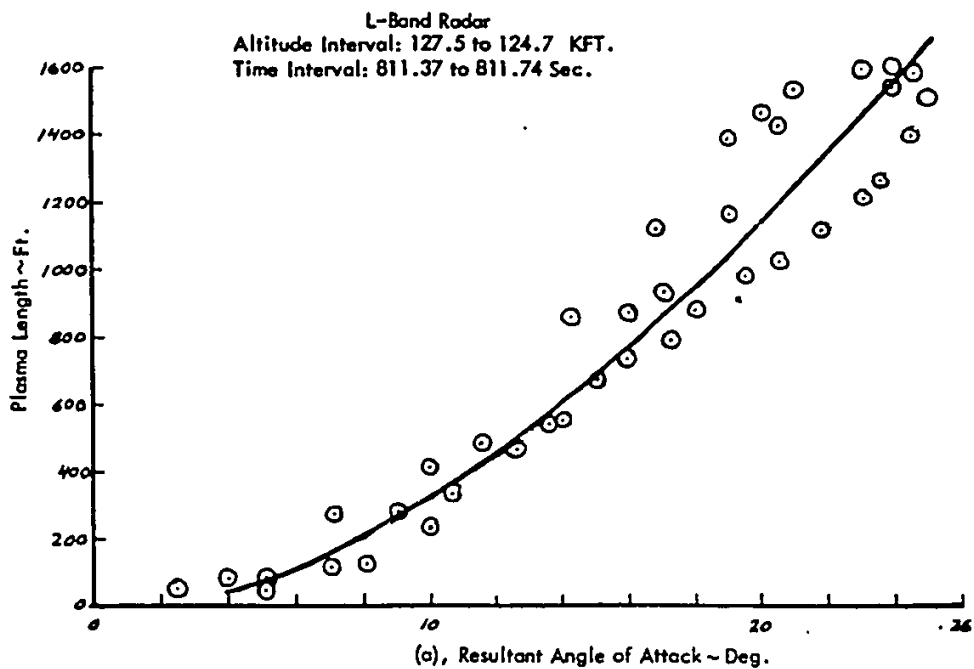

Figure 15



Commander Julian explained figure 16, which shows both the aerodynamic frequencies and the angle of attack, explaining that the curve with the circles represents the smooth aerodynamic frequency, the triangles indicate the frequency of the observables and the scale reading for the angle of attack was given in radians per second. "On A3X-48," continued Commaner Julian, "the triangles matched up quite well. In general, this seems to indicate that the wake length is a function of the angle of attack, given the correlation with aerodynamic frequencies. It is possible that the wake is purely an aerodynamic phenomenon of dumping energy according to the angle of attack; I do not know. It might be a purely aerodynamic event, or

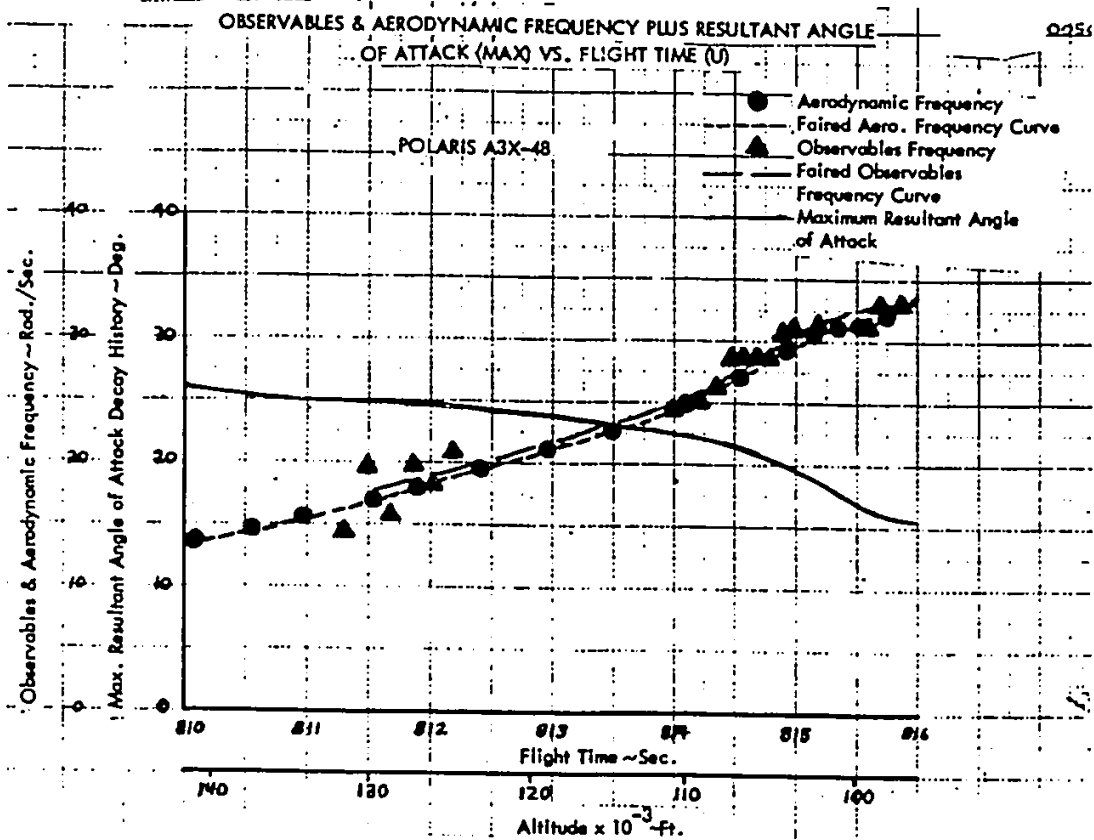

Figure 16

it might be partly aerodynamic and partly related to the injection of the ablations which become ionized immediately. We feel that the ablative materials have much to do with this problem and we are studying this approach to it.

"Figure 17 has some more information, here on the weight-loss rate of ablative products as a ratio of the weight-loss rate at zero angle of attack at the ratio one at zero, and at 30 degrees, which was the highest we saw on the earlier plot, the weight-loss ratio is roughly three. This study has been done for a laminar boundary layer and it indicates that the weight loss is three times as much at 30° as it is at 0°. This certainly supports the previous speculation.

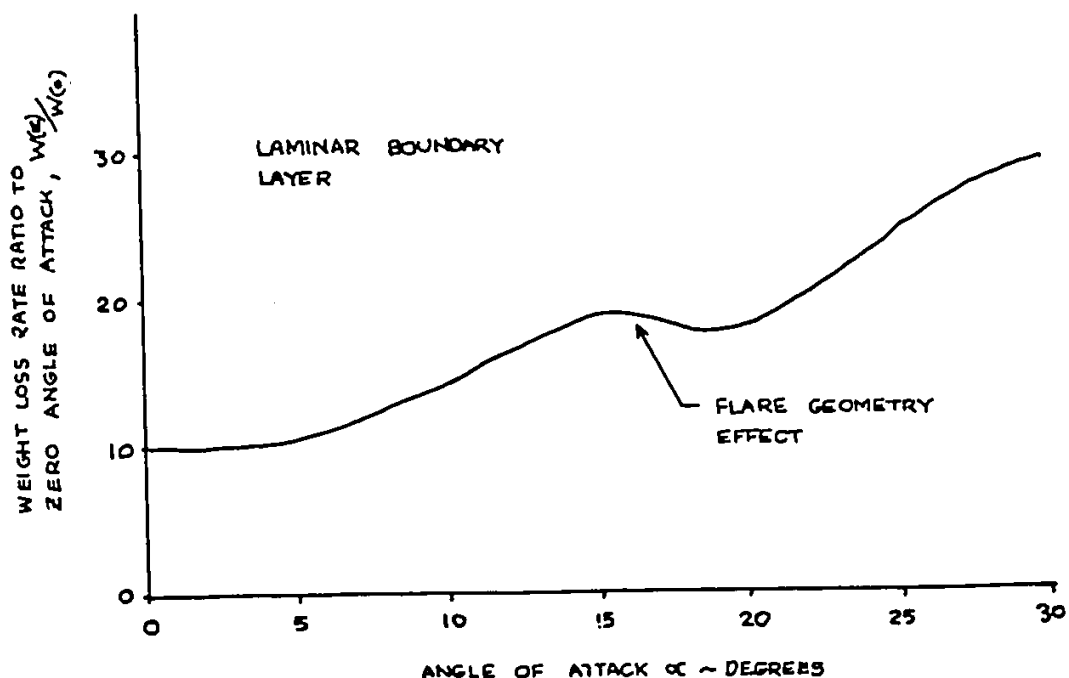

Figure 17

"We have proposed a theoretical and experimental program, figure 18, first to see if we can do anything about suppressing the body wake signature and second, to see if we can do anything about enhancing a decoy wake signature. Remember the past flights were without chaff, and chaff may help this whole problem considerably. We will also go back and review all the flight test data for any wake content that we did not see the first time. We plan to conduct an experimental material program to find a low-temperature ablative material which will keep down this low-temperature rate. As a last resort, we might be able to stabilize the body so the angle of attack does not get 30 degree or more.

## PROPOSAL - WAKE PROGRAM PLAN

- I. COMPILATION OF PAST FLIGHT TEST WAKE DATA
- II. COMPILE, CORRELATE, AND COMPARE AVAILABLE LAB TEST DATA
- III. INVESTIGATE THEORETICAL EMPIRICAL PROGRAMS AND PLANNED FUTURE WORK.
- IV. CONDUCT LAB TEST PROGRAM
- V. DEVELOP AND TEST ADVANCED PX COMPONENTS - D AND C PACKS
- VI. REVISE A3X-13 AND -59 PROGRAM FOR R/B WAKE DATA
- VII. REVISE A3X-13 AND -59 PX FOR WAKE SIMULATION DATA
- VIII. SUPPLEMENTAL FLIGHT TESTS - ABRES
- IX. ADDITIONAL A3X FLIGHTS TO TEST R/S CHANGES TO REDUCE AND/OR SIMULATE WAKE
- X. RECOMMENDATIONS AND CONCLUSIONS

Figure 18

"There is some hope in the fact that the A3X-60, which flew last week, did not give such strong wake signatures from the bodies. We did see strong wake signatures from something else — I do not know what it was — and we flew a different kind of a decoy. We flew the vane decoys, because, from the records and analysis done to date,

they have a much better ballistic match than the dart decoys. The decoys may have been producing some sort of a wake but the people at Lockheed have not identified what body is what.

"We also flew the chaff packages on the A3X-60. We flew the packages, which normally fly in the lead packages E and F, in the far-out positions so we would not deny to the radars in the Kwajalein area the view of the bodies. This chaff apparently survived very well ballistically down to about a hundred seventy thousand feet and no one tracked through it beyond a hundred seventy thousand feet. The reason for this may well be radar problems, for the DR had some trouble, but the analysis has not been completed yet. I am quite concerned about it mainly because the politics of defense/offense gaming in Washington is such that if you have something like this on the record, then they immediately shoot you down.

"We are going for Part 1 now and we have a proposal coming in for Part VI. Part VI states in effect 'Let us build, in lieu of the ablative shells for those two flights, some steel-beryllium shells. Let us see what a clean body signature looks like on DR as compared to this Nylon phenolic signature.' For Part VIII, the supplemental flight test, we are getting a quotation now and hope to soon be building some models of the Mark 2 vehicle, again with plain end and other kinds of ablative materials — probably not too small scale; about a half to two-thirds — to fly on the ATHENA vehicles in the ABRES program.

"We went back to the Air Force to request help in assigning more vehicles to us for this investigation. They immediately and willingly cooperated, and now we have three scheduled — November, December, and January — with others up to a total of 12 in Fy '65 if we need it.

"The PMR operation has ceased for the time being. Johnston Island instrumentation complex is down to change the instrumentation base in preparation for SLEIGH RIDE. We expect to get back on

PMR with 1359 if nothing else comes up in September. Meanwhile we will be looking at what we can be doing to improve 1359."

Commander Julian moved to the subject of a defense system using a low frequency radar of a 100 or 200 megacycle. "Such a system would have disastrous effects," explained Commander Julian, "because of its greater ability to define sizes as shown in figure 19. We would have to accept the fact that decoying against such a radar would be very difficult because the radar would not be fooled by sizes; a successful decoy would have to be given the size and substance of the real re-entry body. This takes the premium out of decoys and leads me to the proposition shown in figure 20. We accept the low frequency radar and do away with the kind of decoys which take up volume and weight to carry something inert. In that shape, and with that weight, we can carry an appreciable yield. Based on the promise for the future in warhead sizing given us at Livermore, we are predicting the parameters around which we can build a re-entry vehicle with the length, weight and ballistic parameters represented by the curves in figure 20.

"Figure 21 shows what such a body could look like — built around these general parameters: 50 inches long, weight of about 100 pounds, ballistic parameter of 2,500. With Livermore's help, we came up with something that looks like the Mark 12, weighs 108 pounds, and has a yield of about 100 kilotons. This system was devised and came to our attention just when we were thinking about decoy problems, low frequency radar and PDD.

"The idea of doing away with decoys and replacing them with these small, 100-kiloton bodies is highly interesting. We decided to call this idea PEBBLES although they are more like small rocks, and we took it up again with AEC. They informed us that the size of the vehicle needed will vary only a little for yields of from one half kiloton up to about 100 kilotons. We decided that this is a very interesting proposal for inclusion into the B3 or A3 prime, or as a mix on the B3.

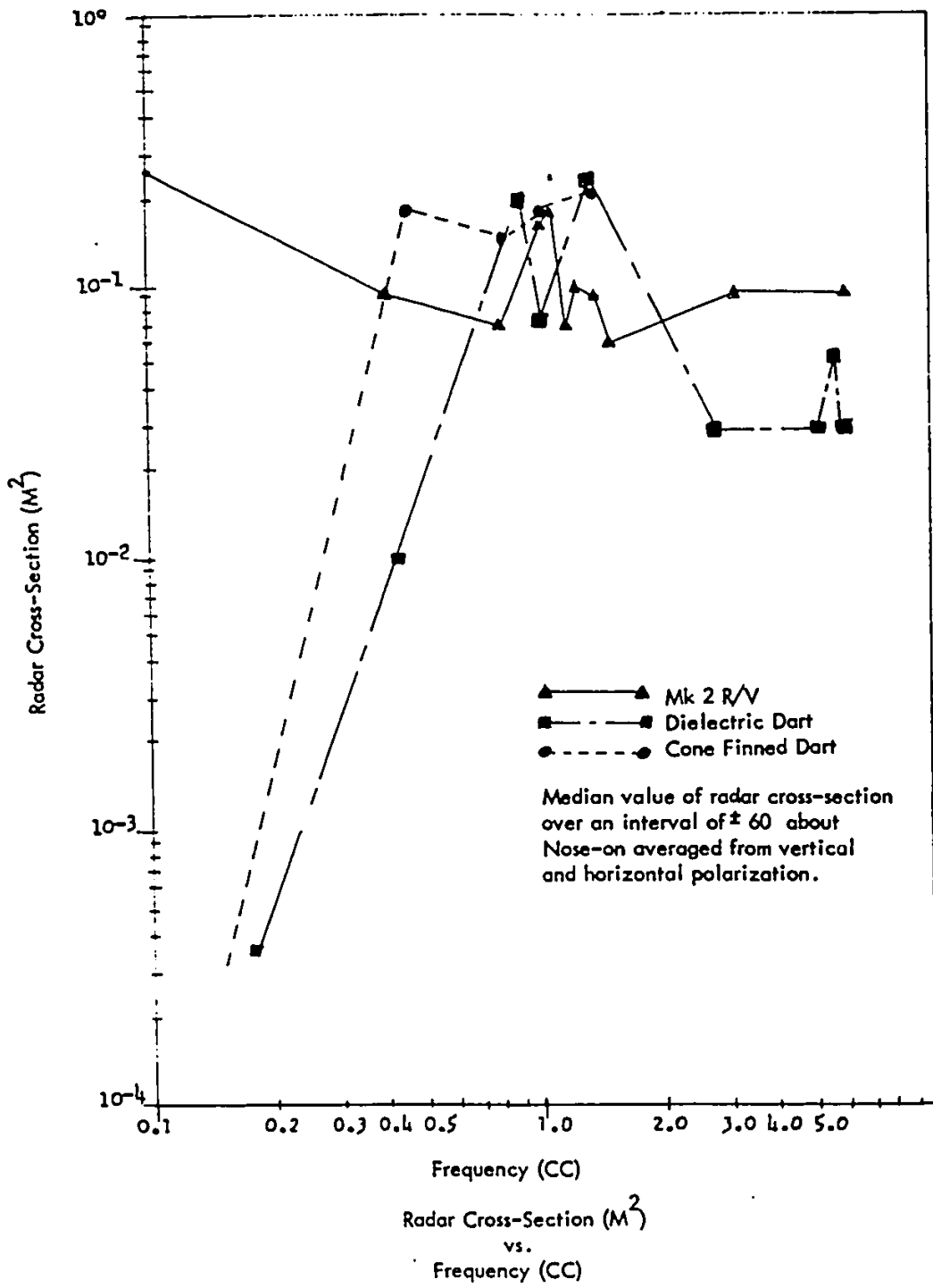

Figure 19



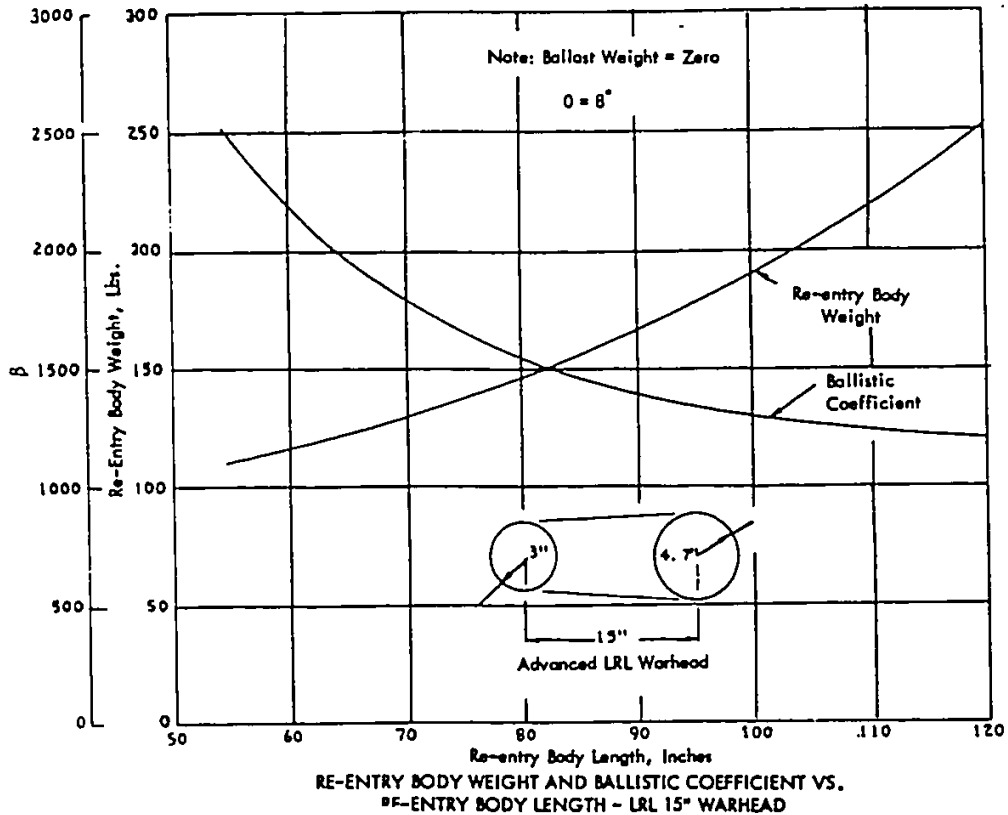

Figure 20

"We could carry 16 of these in the B3 front end as in figure 22. Now with 16 real warheads to take under attack, the defenders will have a very difficult time. The 16 units in the B3, incidentally, will keep the 2,000-mile range. We can put 8 of them into the A3 as in figure 23, and come off with less weight than we now have in the Mark 2 Mod 0 system. All we need is money.

"We looked at this further on the basis that the probability of getting yield on the target is a direct function of the interception. If we assume a PEBBLE-equipped A3, for example, and presume that SPRINT interceptors will be launched at break-out altitudes (and here we have assumed reasonably good chaff coverage down to 170,000 feet), figures 24 and 25 define the probability of survival against the specific SPRINT intercept. The defenders have an

Figure withheld CFRD

engagement time of 4.91 seconds; as there are no decoys, everything he goes for can be a live warhead. Assuming a single kill probability of .81, and assuming that 16 interceptors were launched, we have a sixty percent probability of getting one warhead through as in figure 24. If 20 interceptors were launched against a B3 with 16 PEBBLES, we have a 95 percent probability of getting at least one warhead through, as shown in figure 25.

"In figure 26, we have tried to assess that yield in terms of accumulated kilotonnage on target. First, the number of SPRINT interceptors launched per POLARIS threat, and this figure plots the equivalent yield on target versus the number of interceptors. For 16 bodies at a hundred kilotons, with 20 interceptors launched, we find that represents the equivalent of almost a half megaton on a target. For 10 interceptors you have the equivalent of a megaton

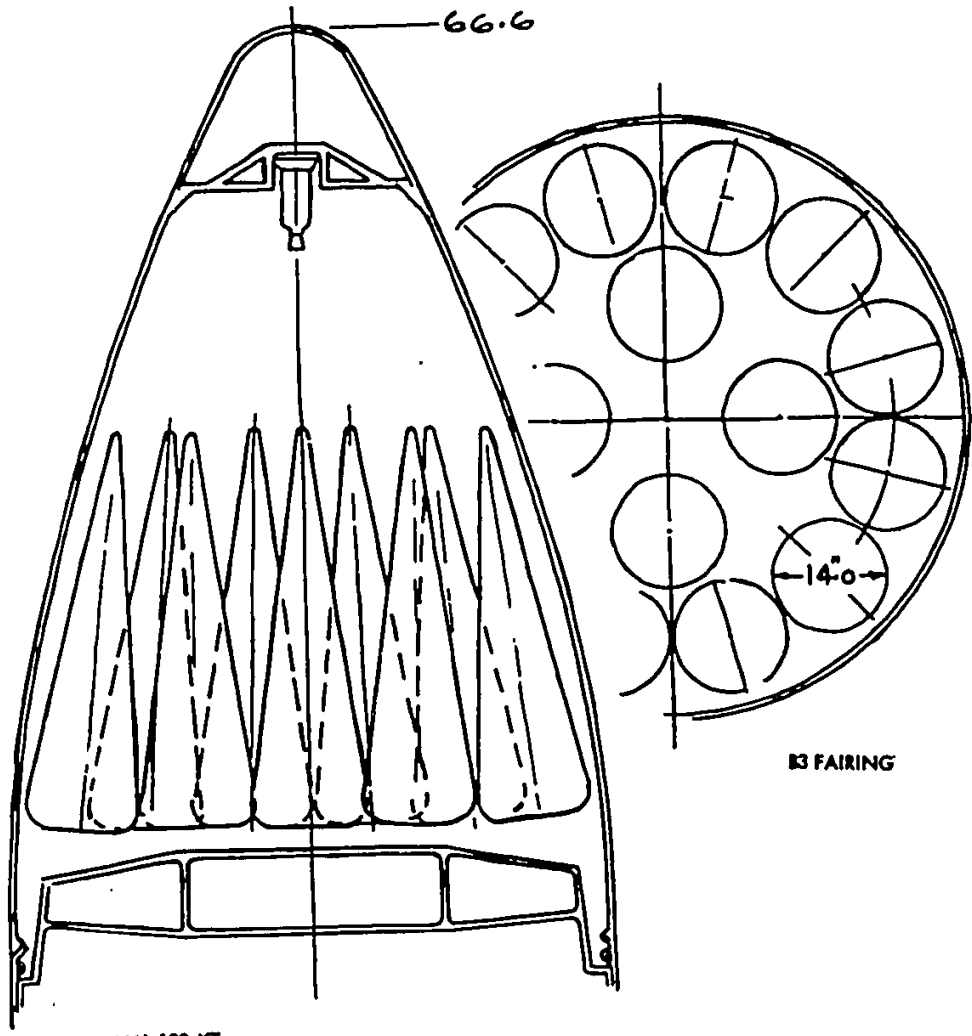

B3 FAIRING

(SMALL) 100 KT

R/V Details	
Total Wt.	108 #
W/H Wt.	60 #
FAF Wt.	10 #
Length	50"
B	1700
g <sup>n</sup> Hardness	300
Cone 1/2 Angle	8°

System Details	
No. of R/V's	16
Total Wt. of R/V's	1728
Structure	315
Propulsion	21
Guidance	77
F/CE Att. Control	230
Electrical	
PX	150

Figure 22



R. V (RE-ENTRY COND.)	112
PROPELLANT	3
SEPARATION HARDWARE	3
STOWED CONDITION	TTE

R/V's COMPLETE (B)	944
STR & BARRIER	.85
ELECT., TILT MECHANISM,	55
MISC.	1084

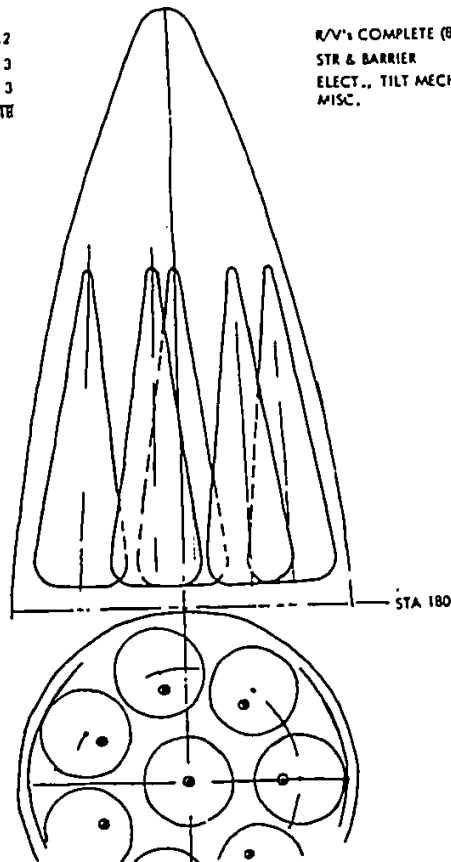
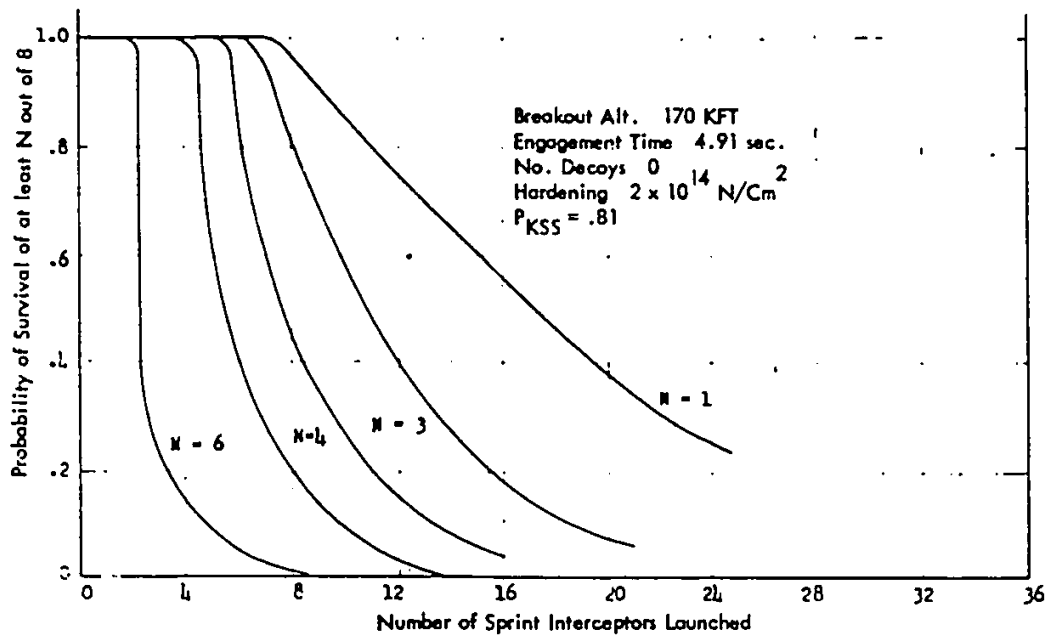

Figure 23

and a half and so on. So such a system with the high probability of survival of a single re-entry vehicle, can accumulate high yield on target.

"We have been wondering how to get such a development started — at least in the prototype format — and we have done the following: We have been talking with AEC for many months in the Re-Entry Committee about such a concept. AEC, Lockheed, Kaman and others have been making the design sketches that you saw earlier. We all feel that the job can be done for 108 or 110 pounds.





PROBABILITY OF SURVIVAL OF AT LEAST N OUT OF 8  
 VS. NUMBER OF INTERCEPTORS

Figure 24

"The AEC is confident that they could develop such a warhead by 1969 or 1970. DDR&E feels that such a program should go forward. They believe it should be in the ABRES effort, the advanced re-entry system Air Force effort. We have discussed this with Colonel Middlecoff just recently. He is not convinced that the Aerospace Corporation, which is running the Mark 12, should do this kind of a job. We both feel that the PEBBLES development requires some sort of a system-bound to build a tube. If you do not define a system, we may build something which may fly, may have the yield, may weigh a certain needed pounds, but may not be able to fly as part of a system because something possibly in the fuzing

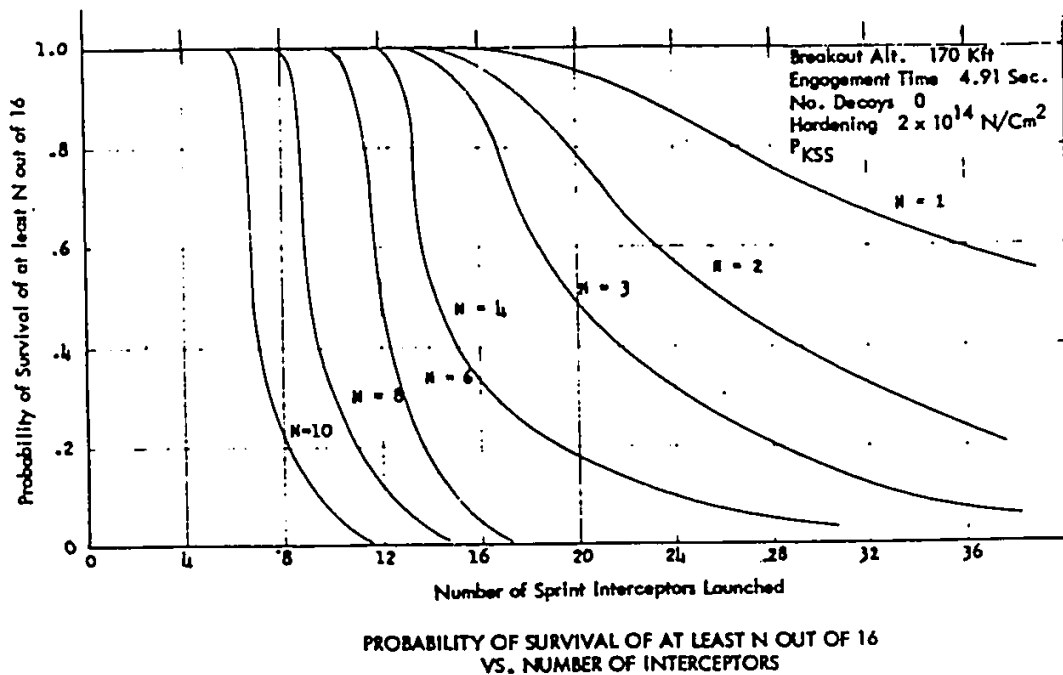
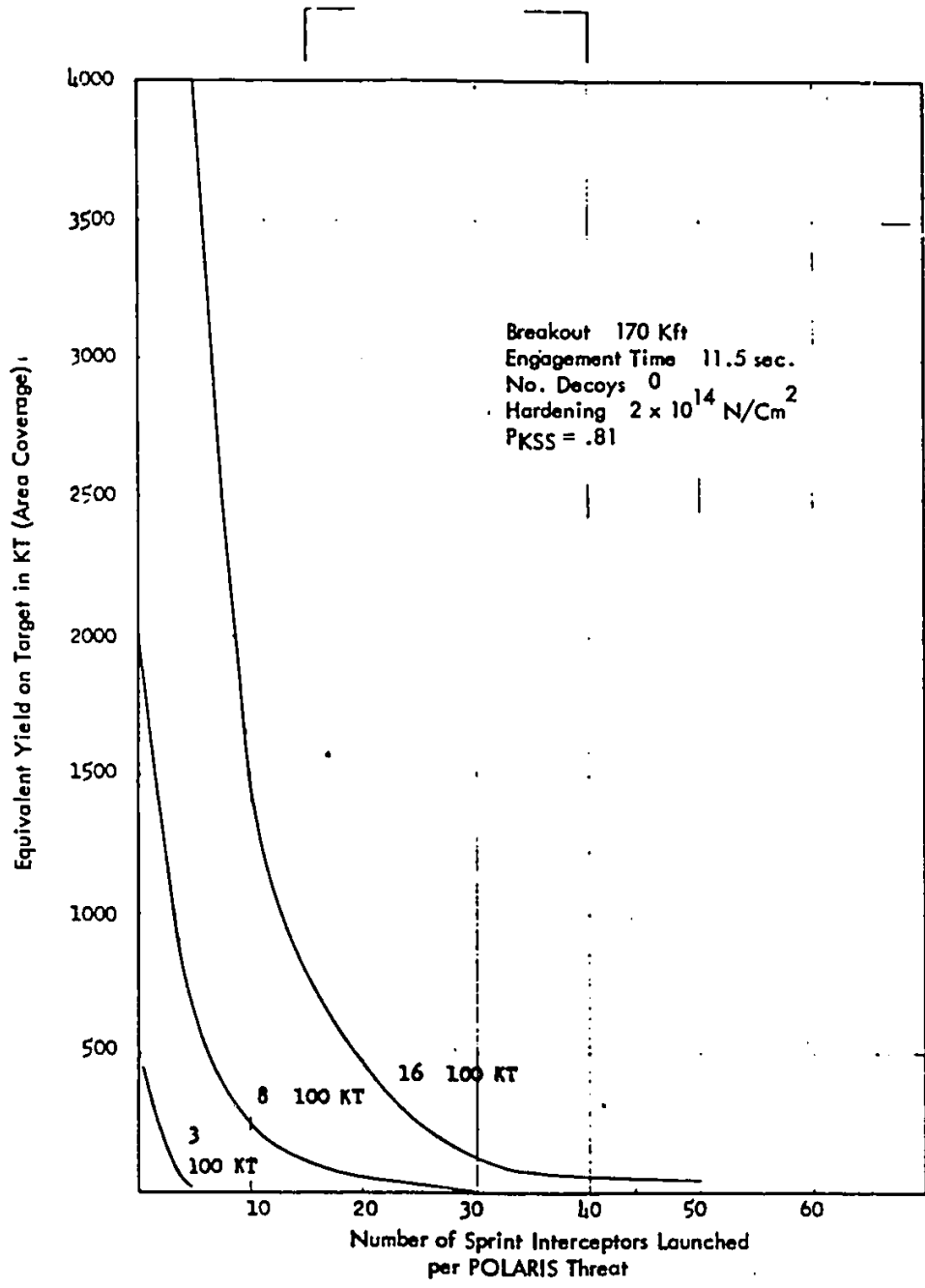

Figure 25

system is too complicated or too sensitive to take the shock loads or something like that. We feel that there must be some sort of minimal system constraint built in.

"We will talk with the DDR&E people next week about Air Force suggested possibility of pulling some of the '65 and subsequent year ABRES money out of ABRES and either delegating to the Navy the job of developing this system with Air Force money or joining in a two-way development with the AEC. This presumes that the Admiral and Captain Sanger approve and also presumes that DDR&E will allow such a step."

Captain Sanger wondered if the Air Force had been pushing this as a gift horse, but Commander Julian assured that he had been making most of the efforts. Lt. Commander Magee observed



EQUIVALENT YIELD ON TARGET VS. NUMBER OF INTERCEPTORS

that the proposal was in keeping with Air Force/JSTPS philosophy of using the POLARIS as a PX package for their MINUTEMAN; one only has to consider their targetting and peripheral concepts of targetting to realize that this program is in keeping with their philosophy. Mr. Peterson inquired if the Air Force had a system-boundary candidate for the PEBBLES approach. Commander Julian explained that they were considering use of TITAN II or TITAN III; Lt. Commander Magee doubted that these candidates were worth serious consideration.

"The time scale for this," continued Commander Julian, "would wait for the AEC development to come to fruition, which would be 1970. We cannot plan to use this idea quickly; if we do accept it, I believe it will represent a tremendous advance in the state of the art.

"The next two topics I have I can run through quickly. They are sort of logistics-oriented. First, we have one way of saving money that we would otherwise have to spend for containers.

"Figure 27 shows a pallet which appears, after a test exercise at NWA for both the technical handling and safety, to be an acceptable substitute for storing re-entry vehicles in the magazines at NWA. The containers can also be used to move the re-entry vehicles back and forth from the magazines to the REB shop or to the MAB for assembly, as in figure 28.

"Now, the only questions that remained after the exercise were ones of safety. That exposed warhead with a light cover, figure 29, is a lot less safe than in an environmental container. We have informally received from the safety group at NWF their approval of such a concept, so we are moving ahead to put the pallet concept in being. Figure 30 shows a re-entry group being handled down to the pallet. That is the cover being removed.

"There is a difference in cost here of a few hundred dollars to several thousand dollars for the environmental container; and



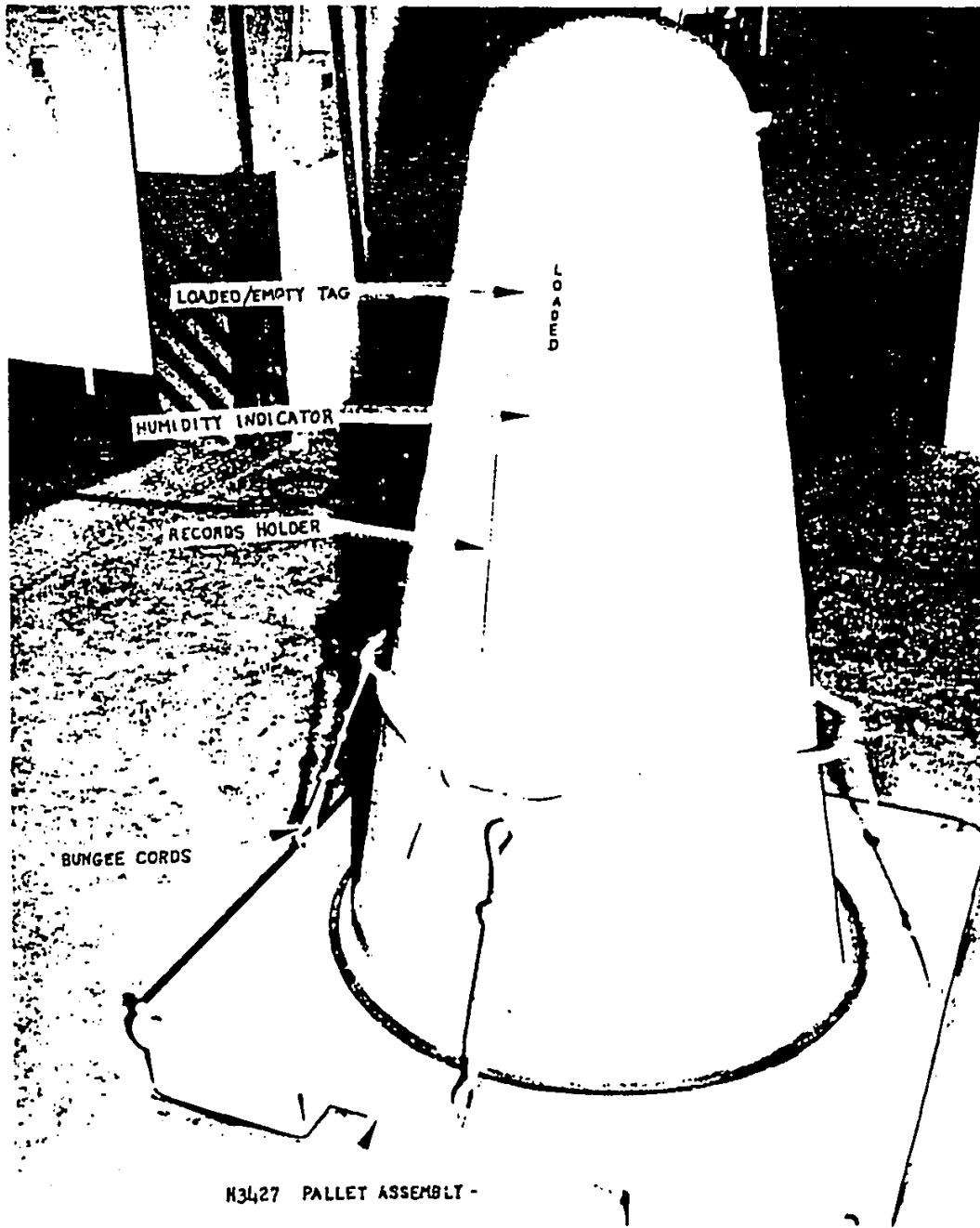

LOADED H3427 PALLET ASSEMBLY

Figure 27

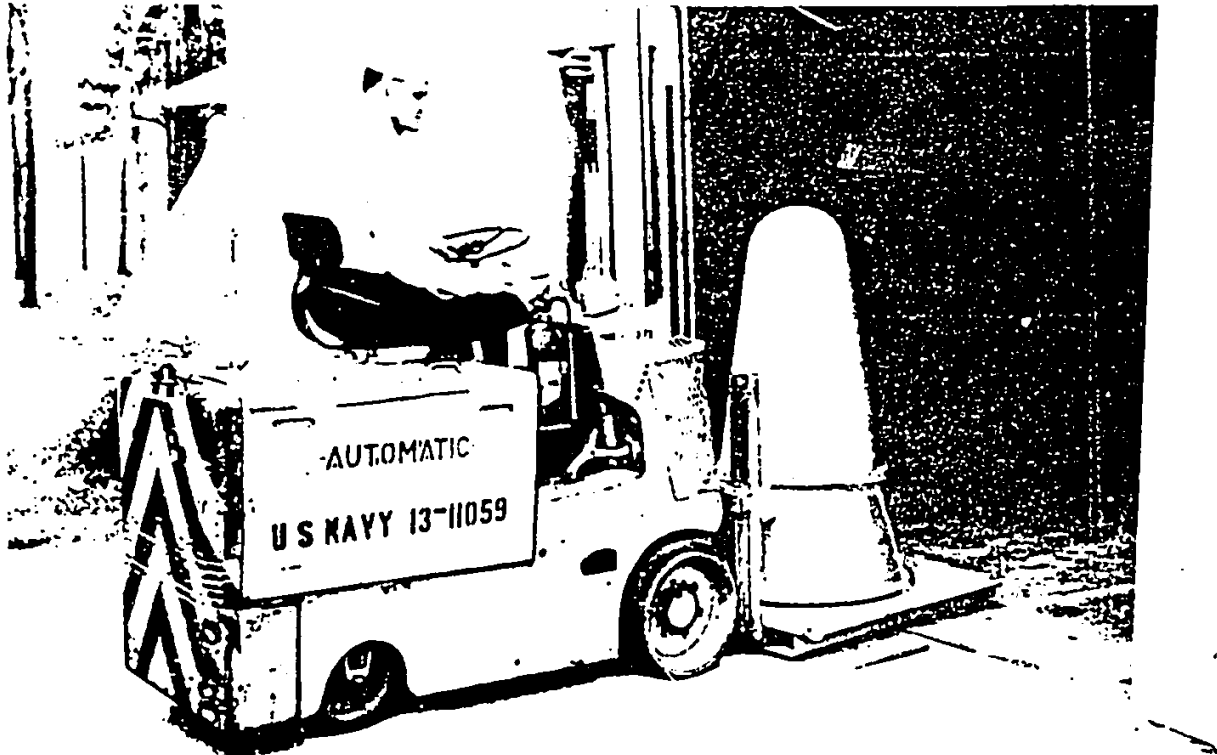

H3427 BEING FORK LIFTED INTO MAGAZINE

Figure 28

before our first ship load we accumulate a tremendous inventory of warhead and re-entry vehicles at NWA. If we did not have something like this, we would have to buy hundreds of containers that would be useful only for the first six months and then would no longer be needed.

"Regarding, PX-2 logistics, we felt that the Fleet did not want either the capability or the troubles of trying to assemble the PX-2 system aboard the tenders.

"Figure 31 is the PX-2 assembly in the base structure without the re-entry bodies. Consequently, we have gone to what we call

UNCLASSIFIED

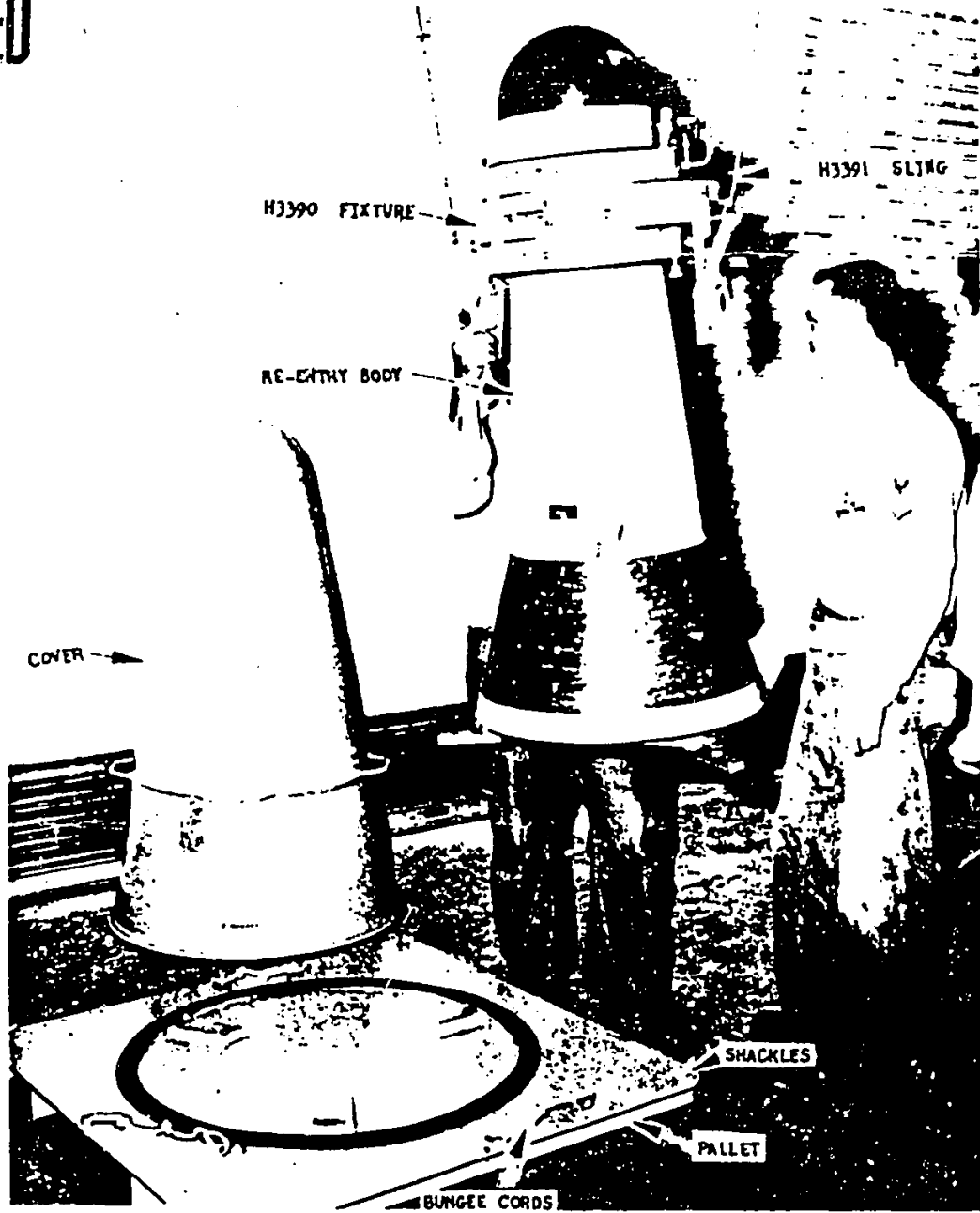

RE-ENTRY BODY SUSPENDED VERTICALLY, WITH H3390  
FIXTURE AND H3391 SLING, OVER H3427 PALLET

Figure 29

UNCLASSIFIED

**UNCLASSIFIED**

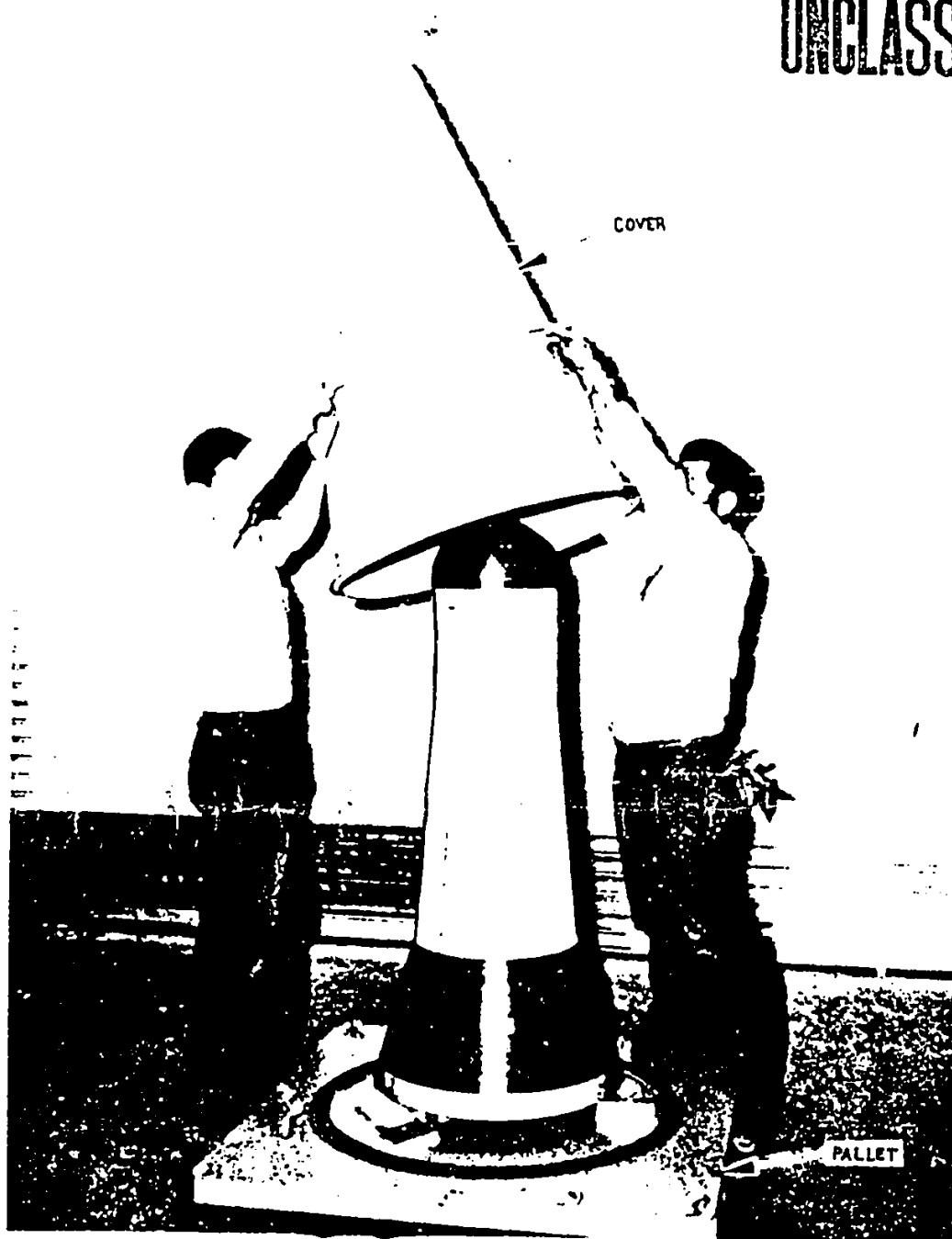

INSTALLATION OF PALLET COVER

Figure 30

**UNCLASSIFIED**

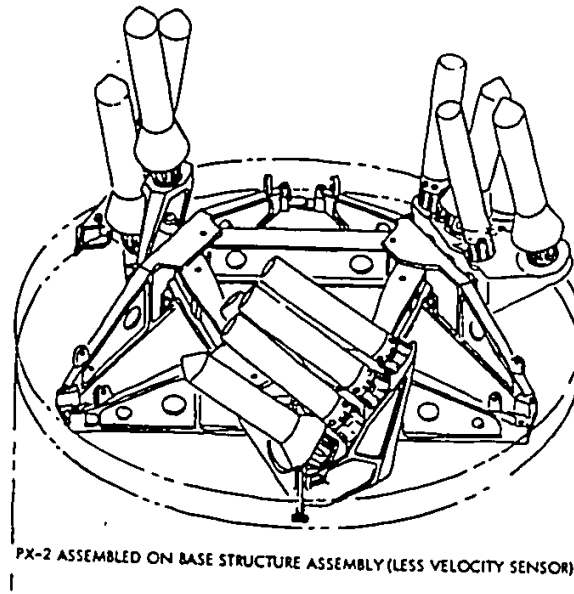
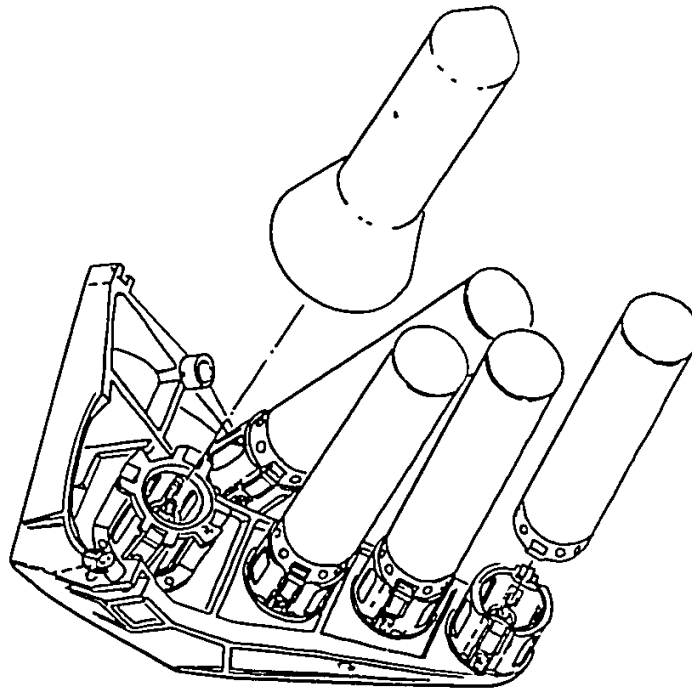

Figure 31

the "wooden tray" concept. Figure 32 shows the tray that goes between bodies.

"We propose to package a PX-2 sub-system in four boxes. One box container would contain the velocity sensor and the associated cabling that connects it to interlocks. Each of the other three boxes would contain one completely assembled tray, with components aboard plus igniters, squibs and cable already connected plus the cables that connect to the velocity sensor. If the tender wanted to convert a missile from Mod 0 to Mod 1, it would only entail making the exchange in the tube, in the shop, or in the magazine.

"Figure 33 shows how it is done in the tube. The only fit required is the mechanical fit of the tray to the base frame and the outer ballistic shell and then connect electrically the cable now connected to the tray to the velocity sensor — no checking, no alignment — everything is all aligned, preassembled.



A-C TRAY ASSEMBLY

Figure 32

"Figure 34 shows a way of exchanging the H3407 lightweight transfer gear. As you can see, you plumb the missile tube. This would be done if we had a bad PX tray, although I don't know how we would ever find it out because there is no checking procedure. But assuming we have a bad tray and wish to substitute a good one, or possibly to change in favor of a tray with different components, we must take the body out; and the H3407 is designed so that we can take the body out, and then without removing the H3407, as in figure 35, pick the tray to be replaced up, and put it on the other ledge. Then, as in figure 36, we drop down in the good one and do this in one operation with the H3407 in the tube. Finally, as in figure 37, we lift the hoist off, close the tube, and conclude my presentation.

RE-ENTRY BODY COMMITTEE DISCUSSION

TRAY REPLACEMENT SSB(N)

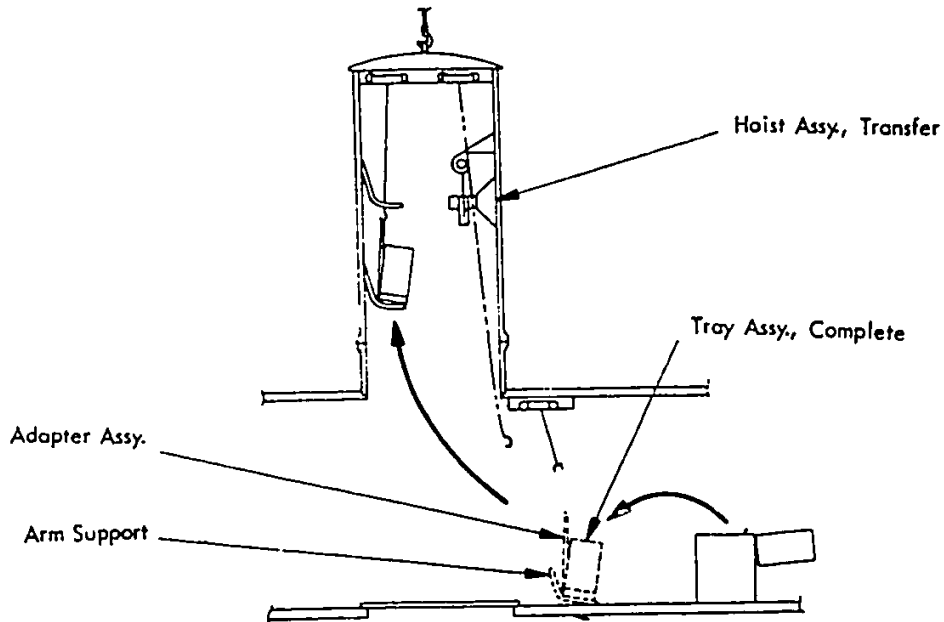

TRAY IS PLACED ON DECK FOR  
TRANSFER TO HOIST ASSEMBLY HOOK

Figure 33

Asked about the timing of the PEBBLES system, Commander Julian explained that he had not studied it, but it would definitely work on a long timing sequence. "We assume a delay of 150 seconds from separation until the pin is pulled from the second gear, permitting it to operate," continued Commander Julian. "The Air Force has a 8-second delay before the I-A sequence starts. We need that 150-second delay because it would take that long for the six bodies to be shot off on their new vectors. However, we do not need to consider this particular type of fuzing system with PEBBLES."

Lt. Commander Magee asked about the B3 with and without the PX package. "As it stands now," said Commander Julian, "the B3 is given an allowed 150 pounds of chaff along with the six

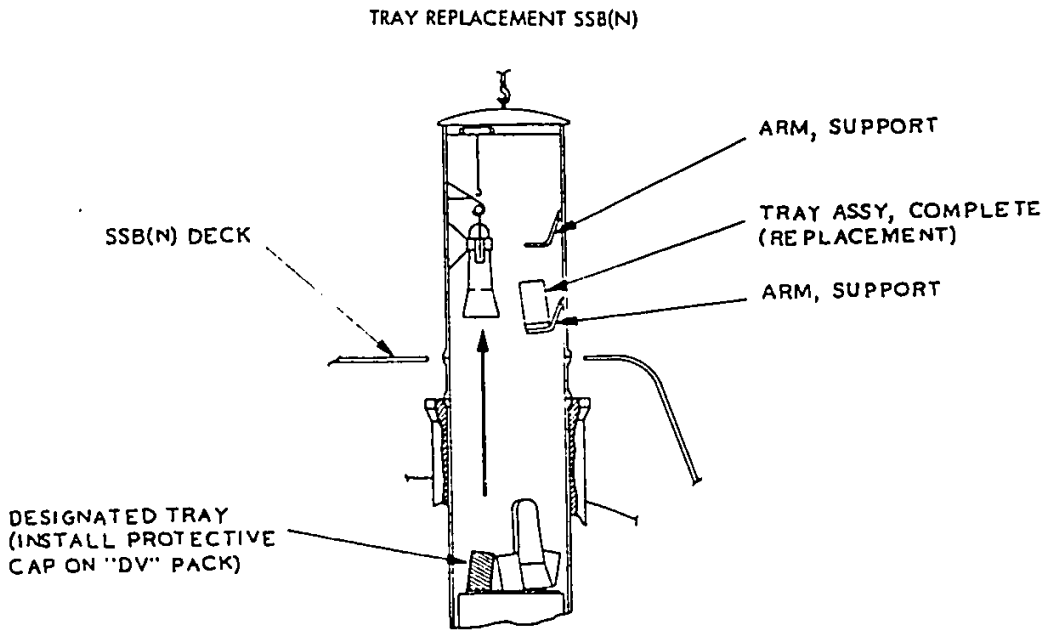

NOTE: NOSE FAIRING REMOVED USING DAVIT (TIME: 1-2 HRS)

Figure 34

vehicles. Other penetration aid items are not going to be stuck in between re-entry bodies, but rather we will replace one or more of the REB's with something called a PX-pack. This pack, while it does not look like a Mark 12 vehicle, will be ejected from the platform in the same way the vehicles are. It would carry penetration aid components such as decoys, ECM, et cetera.

"This system gives us considerable flexibility in that we can use any combination of warheads and PX packs we wish. The PX-pack contents are quite amenable to the Mark 12 size restrictions and we can get up as many as 20 decoys if we need to. In figuring the re-entering items against the numbers of interceptors, we found that these decoys did not have to be very good to give us a high probability of getting a Mark 12 REB in on target."





TRAY REPLACEMENT SSB(N)

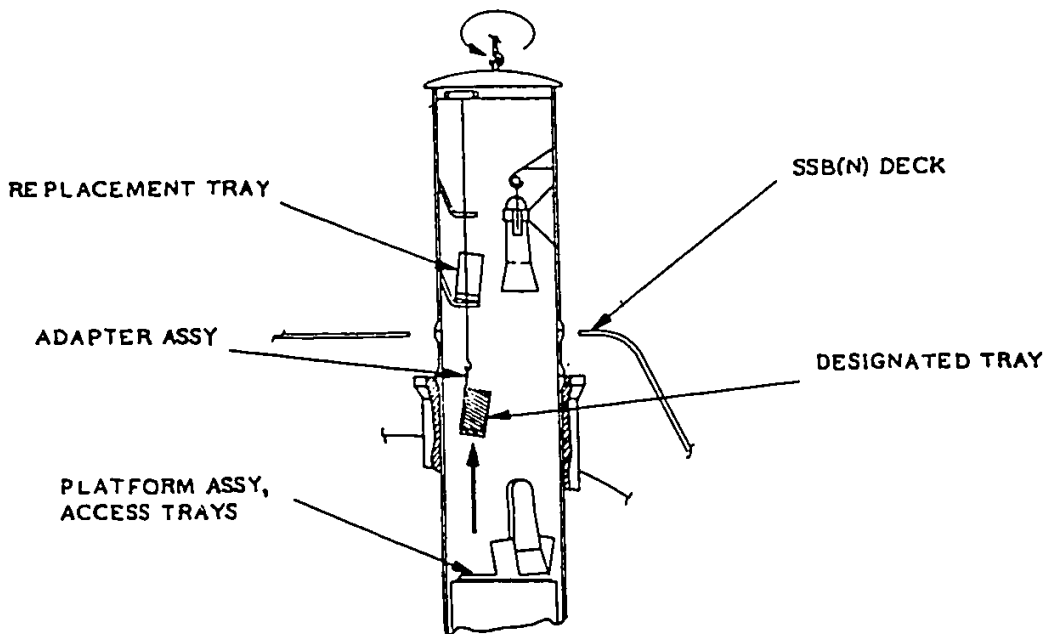

Figure 35

TRAY REPLACEMENT SSB(N)

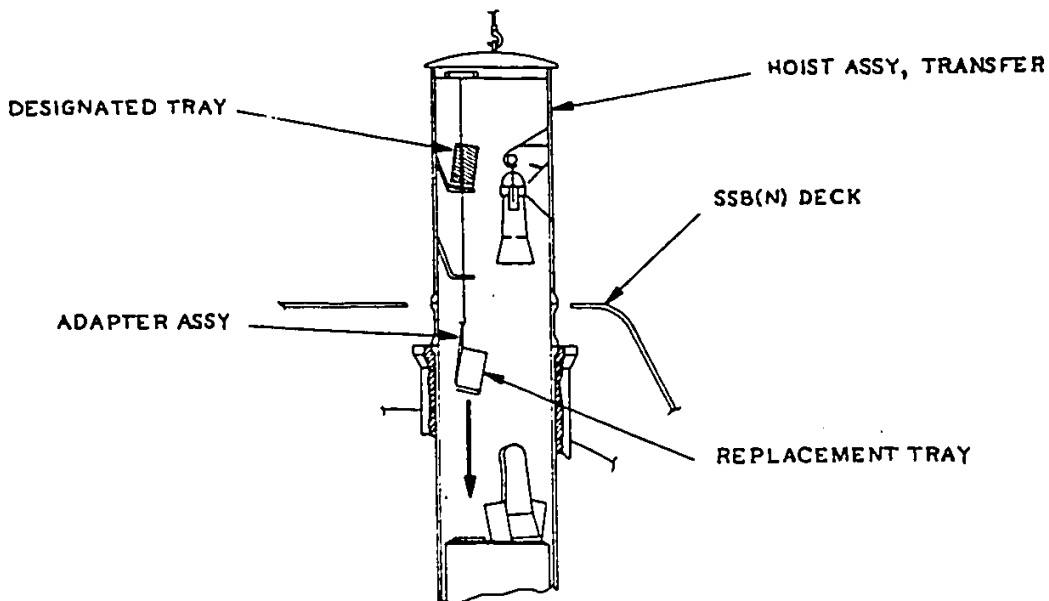
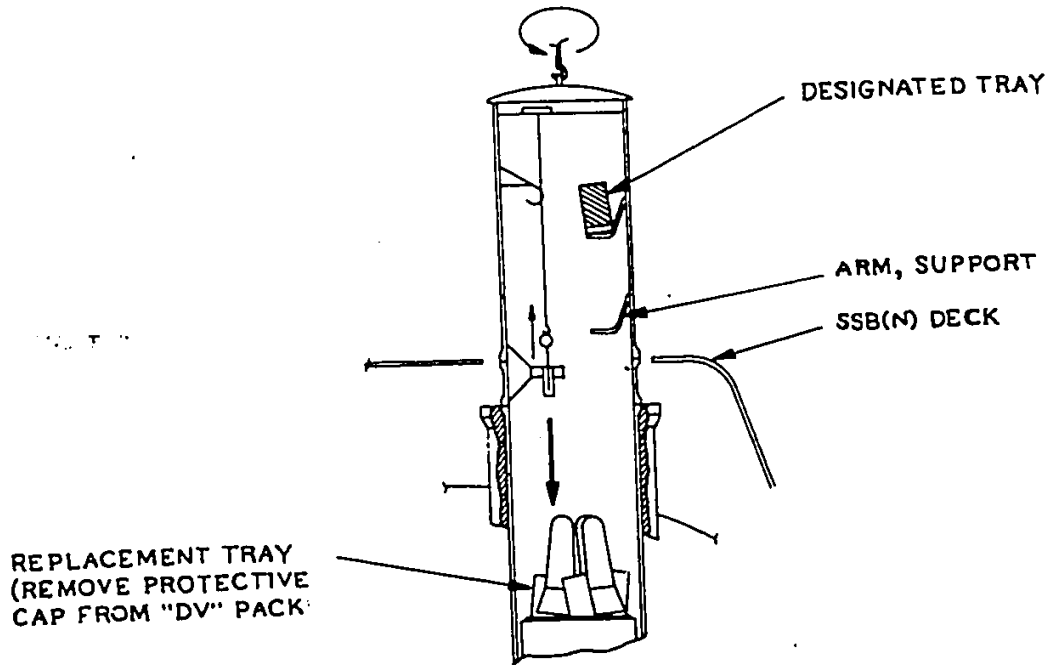

Figure 36



TRAY REPLACEMENT SSB(N)



NOTE: REPLACE NOSE FAIRING USING DAVIT

Figure 37

Mr. Applebaum asked about the fuze proposal and whether the Navy was intending to make its own Mark 12 proposal. Commander Julian replied that the Navy was only proposing to work out the various interfaces that exist with the Mark 12. Mr. Applebaum mentioned that the Air Force may fund the development of a high-altitude radio fuze at NOL; the fuze might actually fit into the PEBBLES concept. Commander Julian noted that the fuze would have to come in at six pounds or less, as that is what AEC allows for it.

Lt. Commander Magee expressed a wish that range not be sacrificed in the B3 program. "We are still fighting a problem with the A3," he continued, "where there are targets that we cannot reach, although these are places where we do not feel a need for



PX aids. Some of this problem comes with the replacement of submarines which may not have the same loading. We also anticipate more frequent core removals in the future, as we are using up cores at a faster rate with the NATO coverage. So we can expect problems with submarine replacement.

"Depending on which loop you are going to put your A3's in or with the A3 substituting for an A2 in certain packaging, we may have a problem in this area because we have got to maintain those alert packages at all costs. Sometimes you find yourself, because of the overhaul schedule, having to put an A3 on A2 in order to keep your weight packages covered; and this is where we make our money. If we do not keep those alert packages over 50 percent, then we are in real trouble, because we can not justify it on a cost-analysis basis."

With no further discussion, Captain Sanger adjourned the meeting for the day.

## MISSILE COMMITTEE REPORT DISCUSSION

### Presentation Given By Captain Christman

"As a starter," said Captain Christman, "my first topic is the problem we are suddenly facing in obtaining conversion money to move the 598-Class submarines into an A3 capability. We may not have any money to do this, and so we are faced with the question of whether it would be better to stay with the A1P missiles, or to devise some sort of A1.5P missile which might include the A2 second-stage motors together with some other A2 features, with the A1 first stage. In short, we would develop possibly a modified missile with some A2 features, particularly in the second stage, where we have had problems with nozzles and with growing separations between the propellant and the insulation. Figure 1 has some figures on this problem which may help us discuss the best approach to a non-A3 missile for the 598-Class.

#### A1.5P

	<u>NOW</u>	<u>ALT A</u>	<u>A2P</u>
F/S	A1P	A1P	A2P
S/S	A1P	A2P	A2P
Range	1109	1250	1553
Probs.	Nozzle S/S reload (72K - Motor)		
Current Rel.	50%	?	85%

Figure 1

"The range figures are based on a study that was made about three months ago, and are typical; we do not have to worry about their exactness. The standard A1P range is about 1109 nautical miles. The A1P has two major motor problems, which I noted. First is the second-

stage nozzle problem, secondly it costs us about \$72,000 every time we re-cycle these motors. The current reliability is about 50 percent.

"The A2P range is over 1500 nautical miles and the reliability is about 85 percent. The alternate A1.5P, which would attach an A2 second stage motor to the A1P, will probably need two test flights. It should give us a range of 1250 nautical miles. The R&D cost of proving this modified version, assuming two flight tests to demonstrate, is about 2.5 million dollars. The cost of adapting the basic A1P missile, i. e., deleting the second-stage motor, building a new motor and changing conduits and similar items, would be about \$236,000 per missile."

Dr. Craven asked whether Captain Christman meant two flights or two successful flights and Mr. Stevenson added that there should be more than just two missiles in the test program. Captain Christman allowed that it was not a highly ambitious test program. Then both Dr. Craven and Mr. Stevenson stated that the test program should provide for two successful flights, because there was no certainty that the A1.5P would have even a .5 reliability figure.

"Remember now," said Captain Sanger, "that this little study was done on the premise that the roof would fall in on us regarding the 598-Class conversion; we are simply looking for the best way out for those submarines."

Dr. Wetmore wondered if the conversion costs for the full A2 would be as high as for the A3, or if they might be enough less to be attractive. Captain Christman did not have the conversion costs, but Captain Sanger noted that the A3 conversion would indeed involve costs that might not be present in an A2 conversion, but both would require ship modification for the longer tubes. Mr. Stevenson added that the second stage of the A2 was about the same length as the second stage of the A1, which made that change seem an attractive means of getting slightly more range without the major ship conversion. Captain Christman noted that he had no qualms about using the A2 rather than the A1, save that he did not have the details of the conversion.

"Conversion would depend on what you want," explained Captain Hammerstone. "You would need a longer tube. You could replace the wiring or you might leave it as is; you could continue with the air launch and you could keep the LPP's."

Lt. Commander Magee observed that the A2 would be somewhat more acceptable in terms of targetting because the A1 does not meet the present philosophy of a secure retaliatory force. Captain Christman added that the costs shown would not apply because the missile would have to be replaced. Further talk concerning the suggested A1.5P brought out the points that (1) the two second-stage motors were identical in terms of mechanical interfaces, (2) the use of the old tube would save a lot of money in ship conversion, (3) there would be quite a bit of R&D cost involved to ensure a working missile -- possibly five to ten million dollars, (4) in all probability four missiles should be fired in the test program, or at least two successful, and, (5) bolt hole matching between stages would have to be checked.

Mr. Peterson felt that no sensible trade-off talks could be held until the conversion costs were known, and Mr. Stevenson agreed, adding that from what Captain Hammerstone had said of the conversion possibility, there was no way of making comparisons or estimates, save that the R&D had best be held down to the minimum.

"One point I have not mentioned," said Captain Christman, "is that we are saving the price of 19 A3P missiles for each of the 598-Class ships. These missiles are much more expensive than either the A1P or the A2P. We are saving enough money to pay for the price of this substitution.

"The question mark in figure 1 deals with the possibility of eliminating the second-stage failures in two areas. The reliability of the A1 without the second-stage motors was 65 percent. In computing this, we merely took the firing history for A1P's, and subtracted those failures which were due to second stages, and just looked at the population of missiles without second-stage failures. We did the same thing for A2

MISSILE COMMITTEE DISCUSSION



to see what they would be; there we came up with 92 percent. We were trying here to find out some achievable target figure, but I am not sure that we found anything that made sense. The numbers may help.

Summary of A1 firings:

Successes . . . . .	31
Second-Stage Failures. . . . .	11
Other Failures, including those unidentified . . . . .	17
Total firings	59

This is the DASO, OT amd FOT firing performance.

Summary of A2 firings:

Successes . . . . .	51
Second-Stage Failures. . . . .	4
Other Failures, including those unidentified . . . . .	6
Total firings	61

The members observed that some suggestions were inherent in Captain Christman's figures: that the problem might lie in the first stage rather than the second; or that the upper limit for reliability of the A1.5P would be about 0.6 in terms of the interaction reliability.

Discussion turned to range problems, with Lt. Commander Magee observing that a degradation of range from 1500 to 1250 n. m. would be quite serious, but Captain Pugh disagreed, stating that the effects in the present areas of operation would be negligible. Captain Christman added that other changes in configuration would help -- as use of the Mark 2 guidance package would add about 150 n. m. to the range, but would require additional R&D costs in making the change together with additional test firings; using the Mark 2 guidance package and the A3 REB, the range would be about 1300 n. m.

"Dr. Craven suggested that we use Dr. Weingarten's model," said Captain Sanger, "to refine our reliability comparison here by eli-



MISSILE COMMITTEE DISCUSSION

minating from the statistics those things we feel have been corrected. I think this should be done. Then, if reliability is still down in the 60 to 65 percent area, we must look further at the failure causes and particularly at the things that would be more susceptible to failure after the substitution. Maybe we can work up a progression from the A1 to the A2, with reliability figures for the progressive stages. I do not think we should consider the Mark 2 guidance system, because it is not really a part of this progression. Again, as I recall, when the Mark 80 was modified for use with the A3, nothing was done to improve reliability per se except the change of a set of cables.

"Now BuShips, for example, is deeply concerned with the Inspect-And-Repair-As-Necessary part of this package. They anticipate that these cables may all have to be replaced on inspection."

"It may be best not to fool around with the missile," said Mr. Stevenson, "and simply to put in the A2 complete. Frankly, I fear that we will harvest a crop of troubles when we start altering these missiles because we all must admit that they have their idiosyncrasies which we may compound simply by altering bolt-holes. Then there must be enough flight tests to determine whether some event is a genuine problem or simply a maverick missile."

"Agreed," stated Dr. Craven, "and even the most optimistic model would have to apply some degradation number for exactly that reason. Even when things are identified as interaction failures, and cured, we still cannot rely totally on the cure."

"In a sense, is this not a need for a program to confirm our reliability in the reliability figures?" inquired Captain Sanger. "We certainly need to have the same level of confidence in these figures as we do for the missiles now in our inventory."

"You can accomplish some things in a sequential test program, if you are lucky," said Dr. Craven, "if the failures that might occur on first two or three firings look like failures that could have been pre-



dicted from the past performance of the equipment. However, it takes only one really bad goof, one unpredicted and unexplainable failure, to ensure that the people in Omaha and the Pentagon would never be satisfied that we had the situation well in hand."

"Getting back to my cost figures," resumed Captain Christman, "I suspect that they are very low in terms of documentation. We should probably have to rewrite a great portion of the 598-Class documentation and OP's -- this could be quite expensive."

Dr. Mechlin wondered about the five-year reliability of the A1.5 missile being proposed. Captain Christman had no established figures for that reliability, but Mr. Stevenson observed that Dr. Mechlin was really pointing to the fact that there would be a definite need for getting more A1 and A2 motors and there are no more A1's being produced. Dr. Wetmore explained that there is enough present A1 hardware for shipfills; the problem would come with the firing rate of the OT's, FOT's and DASA's which would require revival of A1 production where some of the know-how may be lost.

"I think we may be asking the wrong questions here," said Mr. Parran, "for if we consider the savings gained by not converting the 598-Class to the Mark 80 Mod 2, we have one answer; if we consider what the cost difference would be in fire control and guidance, we have a different answer. The suggested approach will put people back in business making Mark 1 inertial components, for instance."

"We just got this problem handed to us in the last 48 hours," explained Captain Sanger, "so it has been a question of taking as hard a look as we can within the available time at all sides of the problem, particularly those areas not directly concerned with cost, things like logistics, the time submarines will be off the line, documentation, and all the possible factors. For example, if we kept the A1, we would have problems in getting first and second stages, and we might have to run through a new OT series. We would need five submarine loads plus the pipeline missiles and the OT missiles."

Dr. Craven observed that if this effort required starting up earlier production lines and producing the hardware, the costs would be excessive; from the number of missiles required, it would seem necessary to restart some production and possibly run through all the production problems again. Mr. Stevenson added that there were many A1 components where life-experience was lacking, and that many of these might have to be replaced, along with motors and guidance packages.

"As the next item," said Captain Christman, "I have a brief summary in figure 2 of the possible failure modes which might be uncovered during the A3 DASO program starting next Monday. Monday's event is the first firing of a tactical A3, although two previous firings, A3X-42 and A3X-43, were near tactical. Now, last January I predicted a failure rate which is shown together with the predicted failure rate for today.

A3E DASO PROBLEMS		
	1-23-64	5-21-64
1. Electrical Failure (A3X-44) (Cabling)	1/33	1/33
2. Stuck Nozzle (A3X-46)	1/33	1/33
3. Second Stage Nozzle (A3X-58)	1/33	1/33
4. Front End Rework	1/33	1/33
5. Miscellaneous a. STAS (A3X-60) b. Umbilical c. AFD Unlock	1/33	1/33

Figure 2

"This failure rate points to 17 successes out of 20, which happens to be the maximum pay-off point for the Lockheed DASO incentive. If we see this failure rate, we should achieve 28 success in 33 firings.

"We still will have some old friends with us. I predict an electrical failure on one out of the 33. We have not yet explained the electrical failure in first-stage flight which occurred at A3X-44.

"In addition to that, we have been having some difficulty with the cabling. We have authorized some additional cable-routing changes, but, nonetheless, I think we must face the possibility of some electrical failures; we really do not have any explanation for A3X-44 and nothing has happened to fix it.

"We have also the first-stage sticking nozzle problem, which has led to a flight failure on A3X-46, but thus far there is no evidence that this problem is any worse. We are also quite nervous about the second-stage nozzle problem (I will show you why on a later illustration) but so far in flight test we have only had A3X-58 as a failure.

"I have no prediction on the front end or for the general area of the re-entry system. The separation rings are an area where we will probably have occasional failures, although since the last change, at A3X-38, we have not had any particular problem in this area.

"We have some miscellaneous problems. There was a reported STAS failure on A3X-60, and the history to date shows 21 opportunities for a successful STAS, with 17 successes and four failures. We are not sure of what happened on A3X-60; this is a question-mark item."

"The A3X-60 appears to be somewhat different," said Commander Julian, "than the problem we had earlier on XH-21. As of last night, in all the experimental work they have done, they still have not been able to duplicate the A3X-60 failure; and it is sufficiently different, apparently, from the earlier failure that the proposed fix, which was electrical isolation, would not appear to solve this one. They were two different failures.

"We will get a firmer grip on this STAS problem in the DASO firings," explained Captain Christman, "because we are going to instrument both the TH-head and the inert head. We will have a better idea of whether STAS actually arrives at the heads and we may be able to correct our previous figures accordingly, or revise our thoughts about what the 17 out of 21 figures mean."

"Originally, a criteria for success was one REB on target," added Mr. Stevenson, "but we could not tell if the STAS failure was common to all three bodies or just to the instrumented body. Thus an STAS indication did not mean that the other two bodies went, nor would an STAS failure mean that they did not. A true accounting of this would require that the STAS be separated and identified at each body. The flights we have tagged as failures -- A3X-25, A3X-26, A3X-50, and A3X-60 -- may not have been for all three bodies."

"We may even have been wiping out the STAS by some shorting that occurs when the rocket motor fires," observed Captain Christman, "because of burning a cable. We have been proceeding on this hypothesis."

Dr. Craven observed that statistical prediction would need some assumptions, including the assumption that the STAS failure affects all three bodies. Commander Julian disagreed, explaining that the three bodies do not have identical time and flight histories; firing of the first body after receipt of STAS might affect STAS for the other two. Dr. Craven replied that statistical inferences would certainly have to include the possibility that no STAS existed as one explanation of why the instrumented body did not receive STAS. Captain Christman disagreed, pointing out that the evidence only extends to the last body, the instrumented one.

"My second problem," said Captain Christman, returning to the report, "is one we hope to isolate to the first seven flights. It concerns a Cannon connector in the umbilical plug and it arises from a change

made during the production of the umbilical which has led to the possibility that sea water can form a shorting path between the various connectors on the outside of the missile once the umbilical is removed. (Captain Christman demonstrated this problem with a sample umbilical plug.) To avoid shorting, we use a double-female connector which is spring-loaded to break the connections between the external plug and the internal cabling once the umbilical has been pulled.

"There are two types of face plate for this arrangement, and evidently in the production of umbilicals for the A3P the wrong face plates were installed. Without becoming too detailed, let me simply say that the umbilical no longer provides this isolation from sea water and it is possible to get shorting on the pins. We have screened all the umbilicals except for seven that are already installed on a SSB(N). We cannot easily take the missiles and break them down, but we are running ten pull tests on each of the umbilicals. We feel that by measuring the force needed to make and break the umbilical, we can pick out the ones which may have a bad plate in them. For the good plugs, having exercised them ten times, we feel there is a good chance that the eleventh time they will work properly.

"In the factory, we screened about 40 umbilicals and found eight faulty plates. If that is the history, then there is one chance in five, or a likelihood that one or two of the seven missiles on the submarine will have a faulty plate."

"We should add that we have tested these umbilicals in salt water with the plate connected," said Mr. Stevenson, "and have not yet had a failure, although we have seen a loading down of the 800 cycle power. This suggests that the sea water can cause troubles in the guidance -- we used a guidance simulator in our tests. It was the general opinion, however, that the guidance would not be adversely affected.

"The next item is highly important: We have had evidence of sticking in the first-stage nozzles during some portion of four flights;

in one flight this led to a flight failure. We have also had some slight evidence in the static test program of nozzle interference. Figure 3 shows a tabulation of this problem with nozzle anomalies. I have a feeling that we may experience this difficulty throughout the life of the A3P missile.

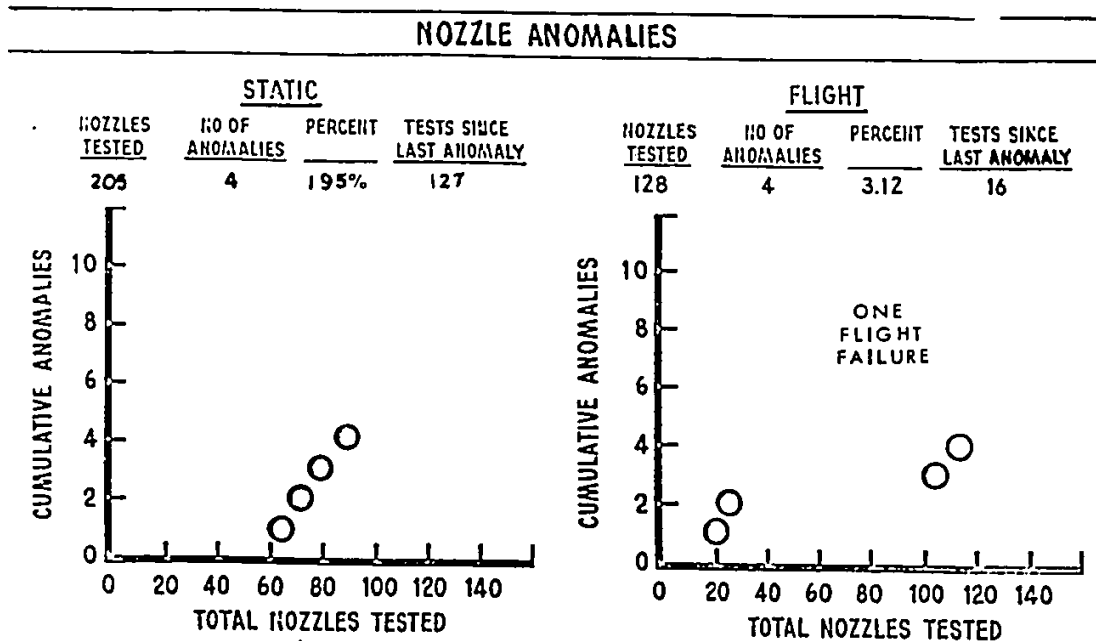

Figure 3

"Figure 4 covers some proposed SPALT's in the areas we have looked at, areas where we have experienced and identified interference between the nozzles and the hydraulics package. We have been looking closely into this problem of interference and are even considering a proposal to open up the area more if there is any indication that we need to. However, we have not yet been able to correlate any of these potential interference areas with any of the failure modes or failures.

"The problem is more difficult than it might seem, because we can only see this in a cold condition. Under actual firing conditions this

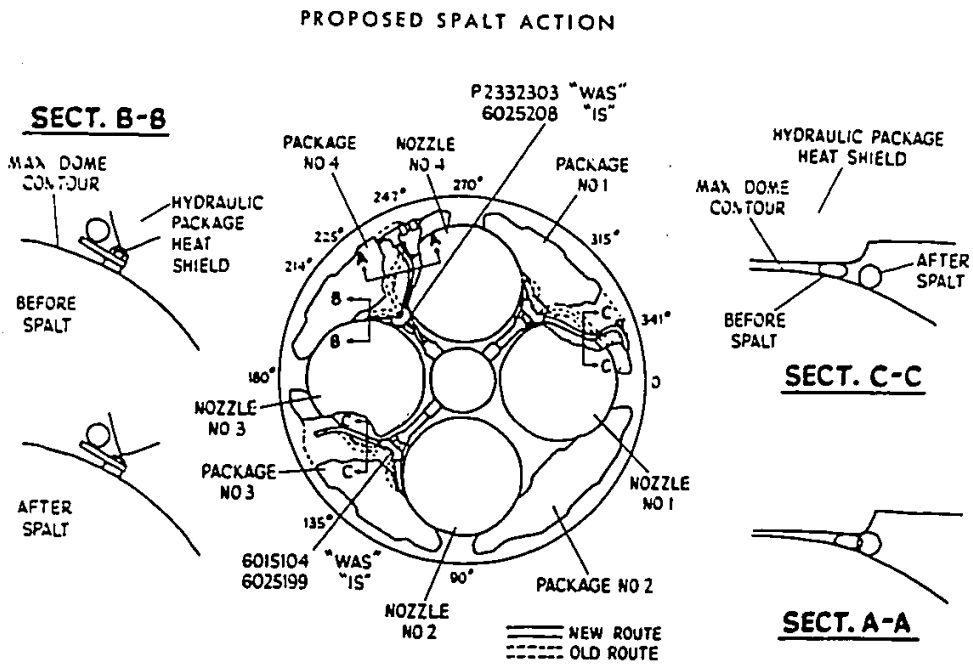

Figure 4

dome is expanding and it is difficult to predict exactly what the configuration of the aft dome would be.

"There were two areas that we looked at. One was the question: Is there something in here which is a failure in the A3X-44? And I guess to date we just have not had anything which is very promising in helping us with either the A3X-44 or the A3's generally. There is no SPALting going forward in this area, even though we are looking at it.

Referring to figure 4, Dr. Wetmore observed that the cable position would seem to suggest that the cable might be both bent and pinched and that over a period of time and exercise might certainly have a fatigue failure.

"That is a very good point, agreed Captain Christman, "and relates to the maximum dome contour. We actually took some domes and built them up to the maximum expanded position, and you can see, in Section B-B, the cable being squeezed between the hydraulic package and the dome. We ought to look at the possibilities, even though the hazard does not exist in the unpressurized condition, to the best of my knowledge.

"The summary given in figure 5 tells its own story; the number of failures has not changed since our last meeting, except that we have had 30 more successes with the Kaiser nozzles. We have done many things in trying to determine any differences that might exist between the Kaiser and the Valley nozzles, and we have found some variation in dimensions and differences in processing. We have been testing Valley nozzles at ABL and have been attempting to force a failure in the Kaiser nozzles in any of the areas where we think a major problem might exist. Thus far we have not even been able to induce a failure, and we have been completely unsuccessful in any attempts to identify the trouble.

A3P NOZZLE PROBLEM			
Supplier	Valid Tests	Success	Failure
VALLEY	136	136	0
KAISER	60	56	4
T-R-W	9	8	1

Figure 5

"There may be some importance in the fact that in two failures the wedge ring separated from the carbon block. I will have more to say about this later."

Mr. Peterson suggested that the totals favor using Valley as the sole supplier and Mr. Parran asked if a reliability problem such as



Presentation Given By Mr. R. Coleman

"During the last half of 1962 the Navy flew a series of light intensity detectors, better known as LID, aboard a POLARIS A2 missile to explore the degree of sky brightness present at these high altitudes," said Mr. Coleman. "These experiments were based on the possible future requirements of a stellar inertial system. Four successful flights were made, and the results were published by MIT.

"The first three flights were made at various times during the daylight hours. As shown in figure 1, all displayed an unexpected rise in intensity level shortly after second stage ignition, reaching a peak on the order of 100 candles per square foot. The intensity then proceeded to drop off until the end of powered flight.

"The existence of this hump caused some concern as it made the problem of star acquisition and tracking somewhat more difficult. We would have expected the intensity to drop all the way down into the noise as we went up higher. We predicted the higher you go, the darker it gets with the decrease in atmosphere but this did not happen. We got the hump depicted in figure 1 coincident with staging.

"Figure 2 presents the results of the fourth flight. A star field scanning device was flown along with the scanning LID which we call SLID. This flight was made at night to optimize the possibility of acquiring a given star which was Canopus. The star was acquired about three seconds before launch, and detected at regular 10 second intervals until  $T + 73$  seconds. The background intensity levels obtained from the SLID were very low, as expected, until  $T + 80$  seconds when the brightness suddenly jumped about two orders of magnitude and maintained until the end of powered flight. This sudden rise coincides in time with the humps of the daytime LIDS, and it is felt that it probably stems from the same mechanism, whatever it may be. There is no

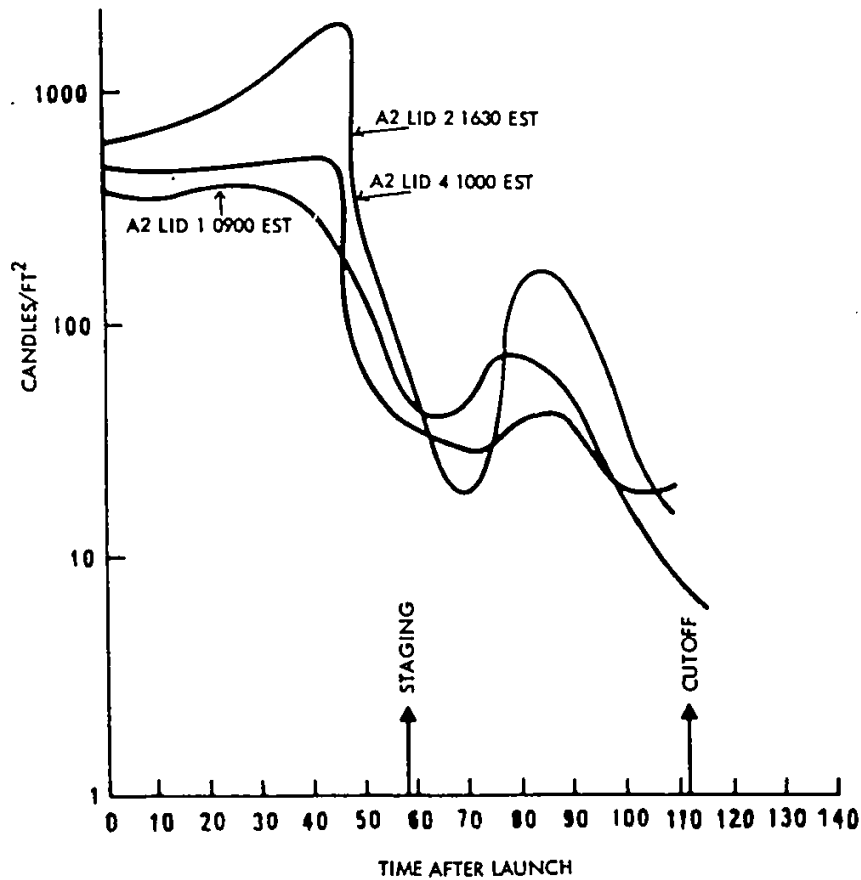

Figure 1

known missile event occurring at that time. The spike at 56 seconds is the staging spike.

"The star field scanner was on board at the same time. It was looking for the star and gave star signatures, but the background DC level, which might be considered an indication of the background brightness, showed the same humps at the same times, so we concluded from that that one of the instruments was not failing, but indeed saw this sudden increase in brightness.

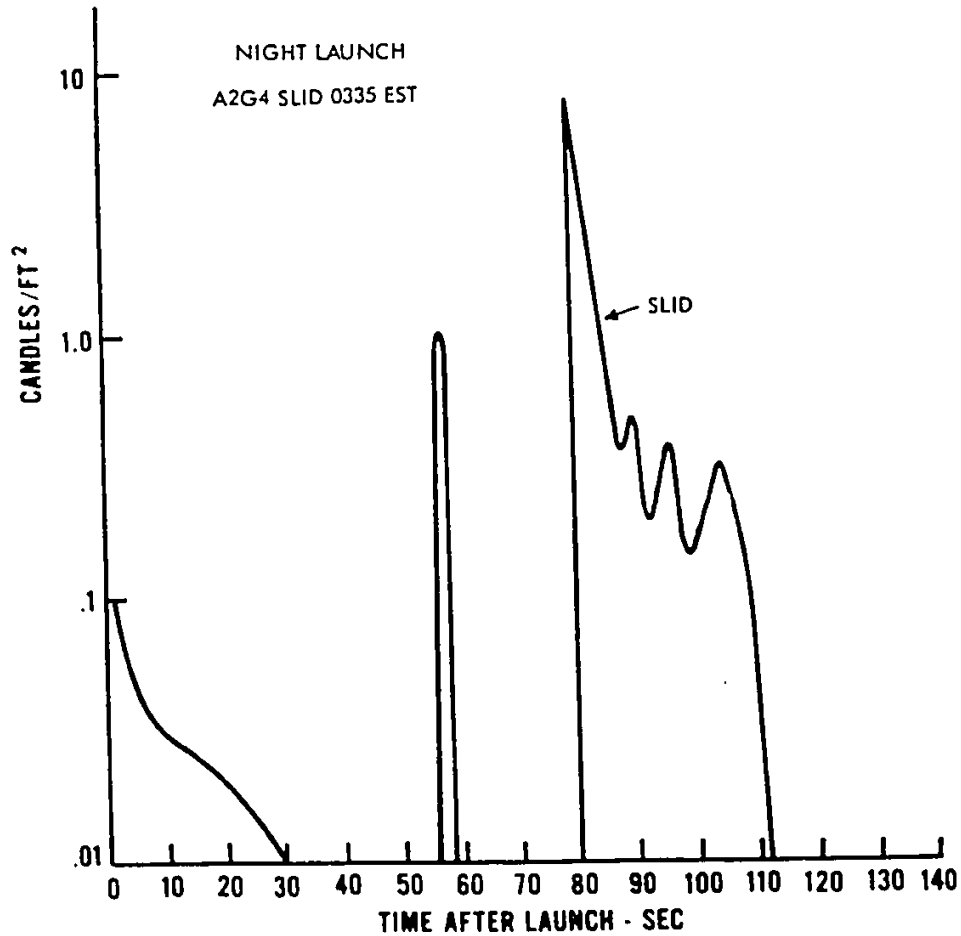

Figure 2

"As we went on further into the A3 program, we looked for the spectral characteristics of the background brightness. These spectral characteristics, which we will get into further on in the A3, did not indicate the colors that plasma might indicate, but rather indicated the colors of the missile flame. The spectral content of the flame turned out to be the same as that observed looking out here.

"The rise time on the chart at 80 seconds was instantaneous as far as you can see by the data. We can not explain it, because nothing is happening on the A2's at that time. We know that nose fairing separation on the A3 takes place about that time. The engine is burning. The first stage cuts off about 58 seconds, as you can see on figure 2. The second stage takes over at T plus 58 actually, and burnout occurs at about 110.

"At 80 seconds, the altitude is about 200,000 feet," said Mr. Coleman, answering a question from Dr. Frank.

"The fact that this peak drops when the motor shuts off implies that the cause is in the motor," remarked Mr. Parran. "Nothing is happening at 80 seconds to cause a three order magnitude change."

"You still have this aerodynamic Q but by 90 or 100 seconds it is all gone," said Mr. Stevenson. "You do not even have aerodynamic Q that you can measure by a hundred. So if that were it, it ought to drop off at 100 seconds."

"T plus 80 as a maximum is around Mach 8 to 9," continued Mr. Coleman. "It builds up and finally hits about Mach 12 I believe on the A2.

"The light sensitivity device is located in the equipment section. On the A2G4 the star field scanner was on the guidance system pitch axis. The LID was on the window that it was looking through in the equipment section. The SLID was 90° out, scanning 35° forward.

"The POLARIS A3X flight test program was getting underway about this time and we put one of these LID's on the A3X-7. The results of this experiment are shown in figure 3. The background light decreased until staging, when a step increase was observed again. Instead of decreasing with time, the light level remained constant at a high level of roughly 200 candles per square foot throughout the rest of the flight.

"The MMRBM specification called for tracking a star through a

FIRE CONTROL AND GUIDANCE COMMITTEE DISCUSSION

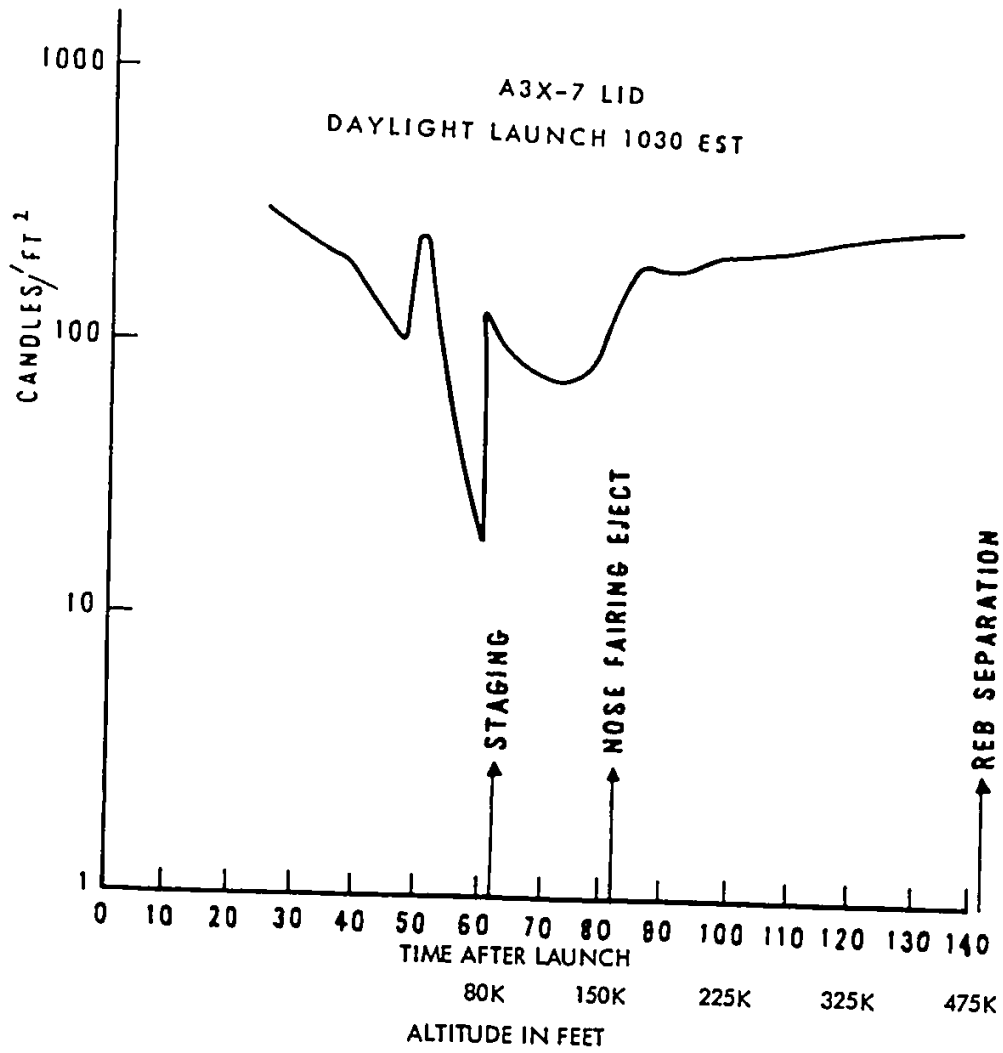

Figure 3

100 candles per square foot background. During this daylight flight the intensity was somewhat higher than 100 candles per square foot. The telemetry data ended at end of powered flight, so it was not known if the light levels decreased after motor burnout. However, on subsequent tests it was learned that the missile starts tumbling immediately after motor burnout and the light intensity data becomes meaningless.

"On this flight we did not have data beyond 140 seconds. On other flights, we took data all the way out to 170 or 180 seconds. However, as soon as the second stage burn-out occurs, the missile starts tumbling and we get alternate high-low-high-low indications, so we really can not tell if the background drops off to nothing or continues at this level.

"The MMRBM specification of tracking a star through 100 candles was based on the state of the art detecting devices at the time, what they could see through and detect. Several theories have been advanced to explain these high levels, or the so-called LID phenomena as it became.

"At T + 80, the A3 nose fairing separates and exposes the re-entry system. Some of the theories about what could happen when the nose fairing comes off were as follows: atmospheric self luminescence of the ionized air; reflection of missile flame and/or sunlight from the missile shock wave; scavenging of exhaust particles forward along the missile body creating a scattering media in the line of sight of the photometers; missile pluming forward of the line of sight; multiple reflections from the missile window and its mounting surfaces; radiation from shock heated ablation materials from the forward section; and about 10 other minor probabilities.

"With all these theories, and very little data to substantiate any of them, the Special Projects Office was requested by DOD to continue investigations in an attempt to definitize the LID phenomena mechanism because of its obvious impact on the MMRBM stellar requirements. As a stellar inertial requirement no longer exists for the POLARIS program, further work was carried out on a not-to-interfere basis with the prime

objectives of POLARIS. To this end, a four-phase program was implemented which consisted of the four items listed in figure 4. The first phase was the determination of second stage motor spectral and intensity characteristics at sea level and altitude, in order to correlate with the spectrum actually seen and determine if there is any spectral shift at altitude. The second one was an analysis of A2 and A3 missile windows with regard to the light reflections from the mounting surfaces. Number 3 was an analysis of A2 and A3 ablation possibilities to determine the composition and quantity of particles of ablation from the nose sections. The fourth one then was actual flight test of four A3 missiles with photopic and spectral analyzers aboard. We had the A3 with two special windows at the equipment section level.

"The spectrophotometer that we had on board, or SPOT, shown in figure 5, is a spectroradiometer designed by MIT which incrementally scans from 3600 to 6800 angstroms through 27 interference filters. The field lens has a 37-millimeter diameter and an 82-millimeter focal length. A 0.070 inch aperture limits the field of view to approximately  $1^{\circ}$ . The photomultiplier circuitry, utilizing an RCA 7029 logarithmic photomultiplier tube, has a decay time from saturation to the dark level of 2 milliseconds, yielding a frequency response of about 500 cycles per second. I am told that this represents an advance in logarithmic photomultiplier devices.

#### LIGHT INTENSITY PROGRAM ( 4 PHASES )

1. Spectral and Brightness Characteristics of Second Stage Motor Flame. MIT/NRL
2. A2/A3 Window Analysis for Scattering Effects. MIT
3. Investigation of Ablation Theory. LMSC
4. A3 Flight Tests with Brightness and Spectral Measurement Equipment Aboard. LMSC/MIT

Figure 4

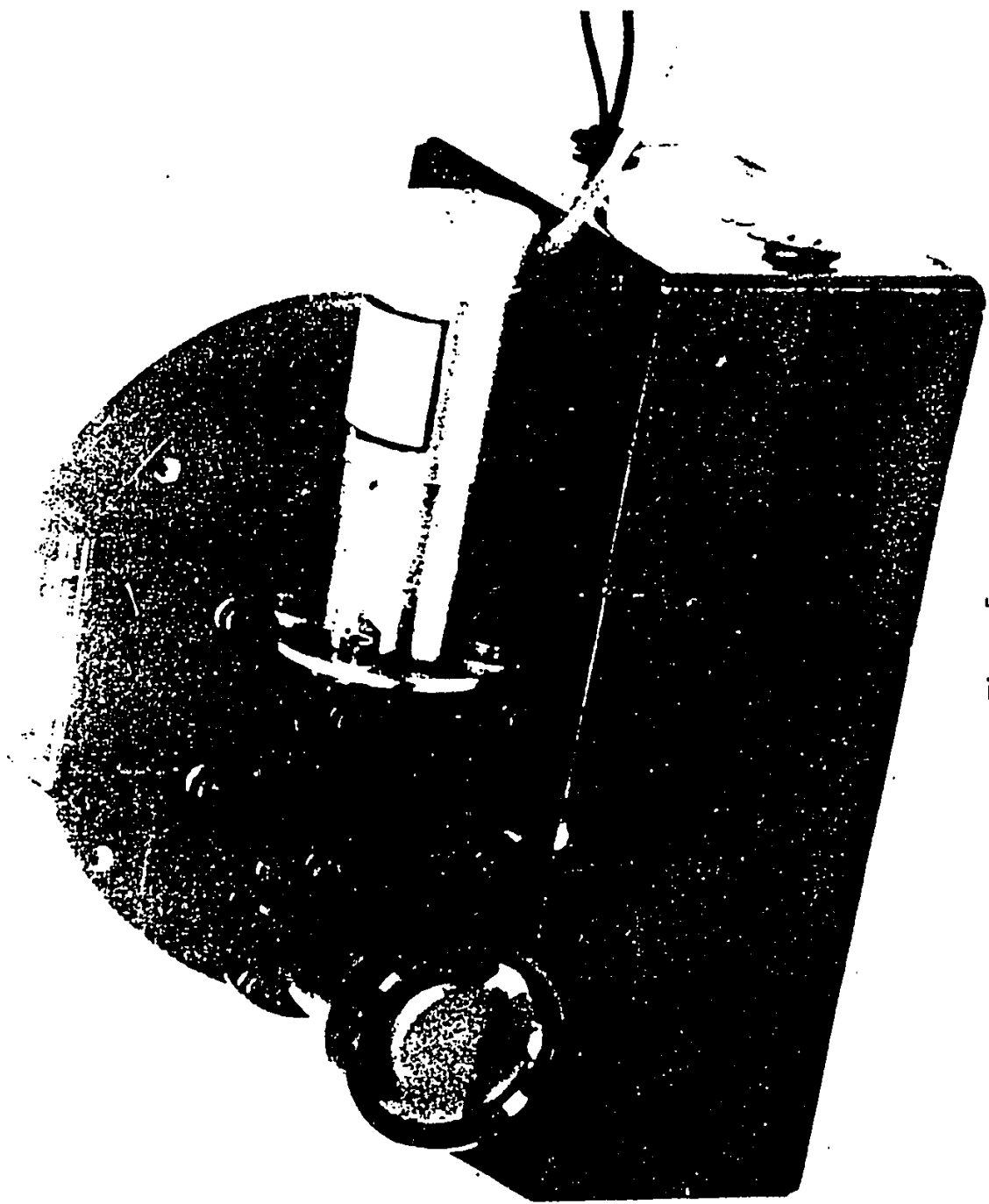

Figure 5



## FIRE CONTROL AND GUIDANCE COMMITTEE DISCUSSION

"The filter wheel of SPOT is shown in figure 6. The interference filters are mounted on a rotating wheel so that they are sequentially placed in the optical path. In addition to the 27 interference filters there are three other positions on this wheel: an open position which indicates an integrated light level; an opaque position which gives a dark or no signal reference; and a long half life radioactive phosphor of constant light output which monitors the sensitivity of the instrument. This has a life of approximately two and one-half years. From 3600 to 5000 angstroms, the interference filters are nominally 100 angstroms wide; from 5150 to 6800 angstroms they are nominally 150 angstroms wide. The wheel rotation rate is roughly three revolutions per second.

"Figure 7 is the LID, or light intensity detector, a photometric device employing a logarithmic photomultiplier unit containing an RCA 7029 photomultiplier tube. The field lens has a 37-millimeter diameter and an 82-millimeter focal length. The system was limited in order to have a  $0.62^\circ$  field of view. The decay time here was approximately 20 milliseconds or a frequency response of about 50 cycles per second.

"Four A3 missiles were specially modified, as I pointed out, with two extra windows and bracketry for installation of LID and SPOT. Two night and two day shots were made to measure the total background brightness and the spectral content thereof.

"The results of the two night shots, A3X-48 and -50 are shown in figure 8. The total brightness profile is a function of time after launch. Both LID and SPOT indicate identical results on both flights, so only the LID data is shown here. At second stage ignition, a step increase in brightness was observed with another hump coincident with the nose fairing separation event. The third smaller perturbation is coincident with re-entry system separation. Although the peak light level of about 10 candles per square foot is not high enough to disturb star discrimination, the occurrence of the hump is contrary to the predicted light levels at that altitude, and probably stems from the same mechanism observed in the A2 flights. The last two A2 shots were day flights — one around noon; the other around 7:30 A. M. We found that in daylight the pertur-

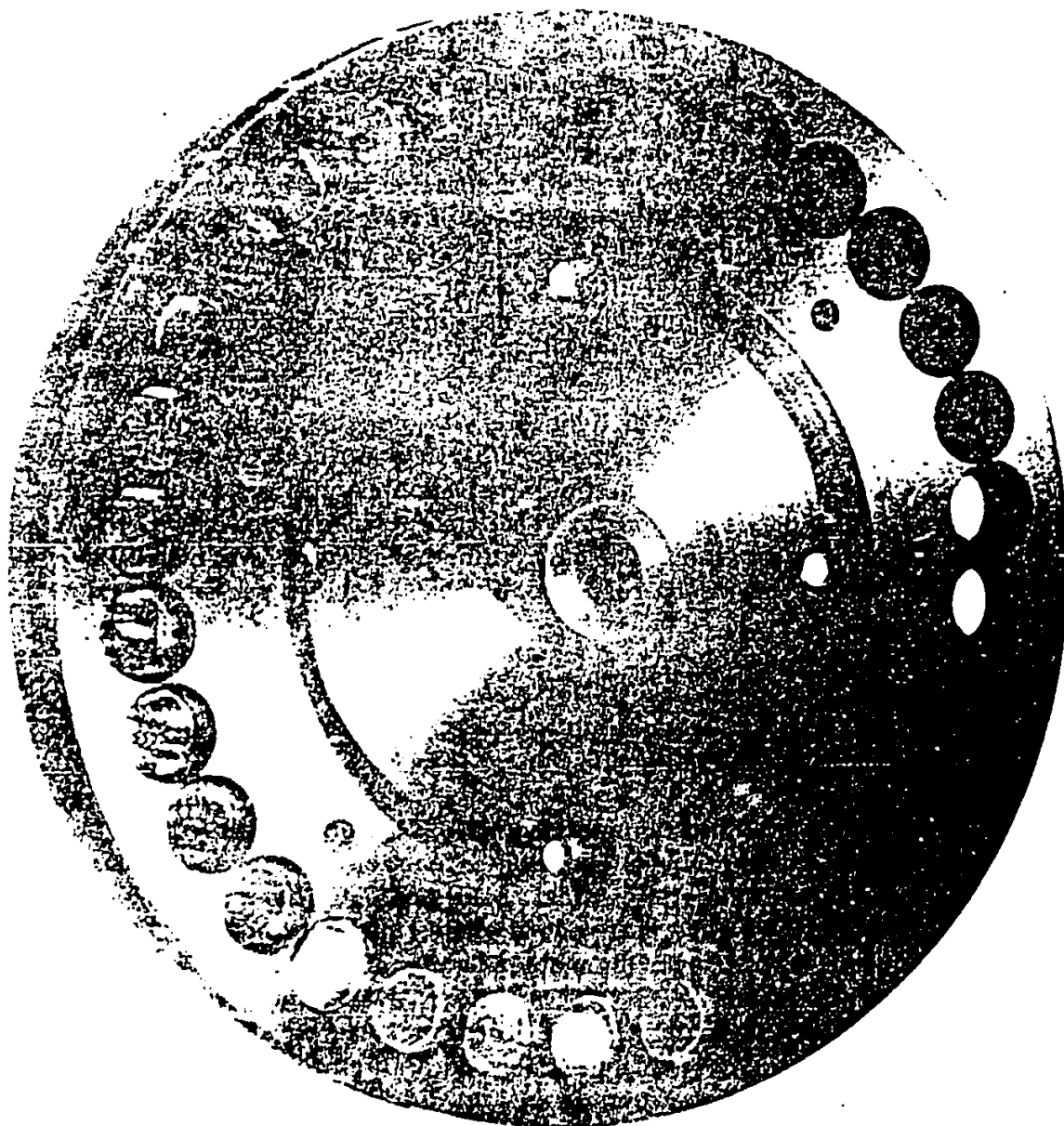

# FILTER WHEEL-SPECTROPHOTOMETER

Figure 6



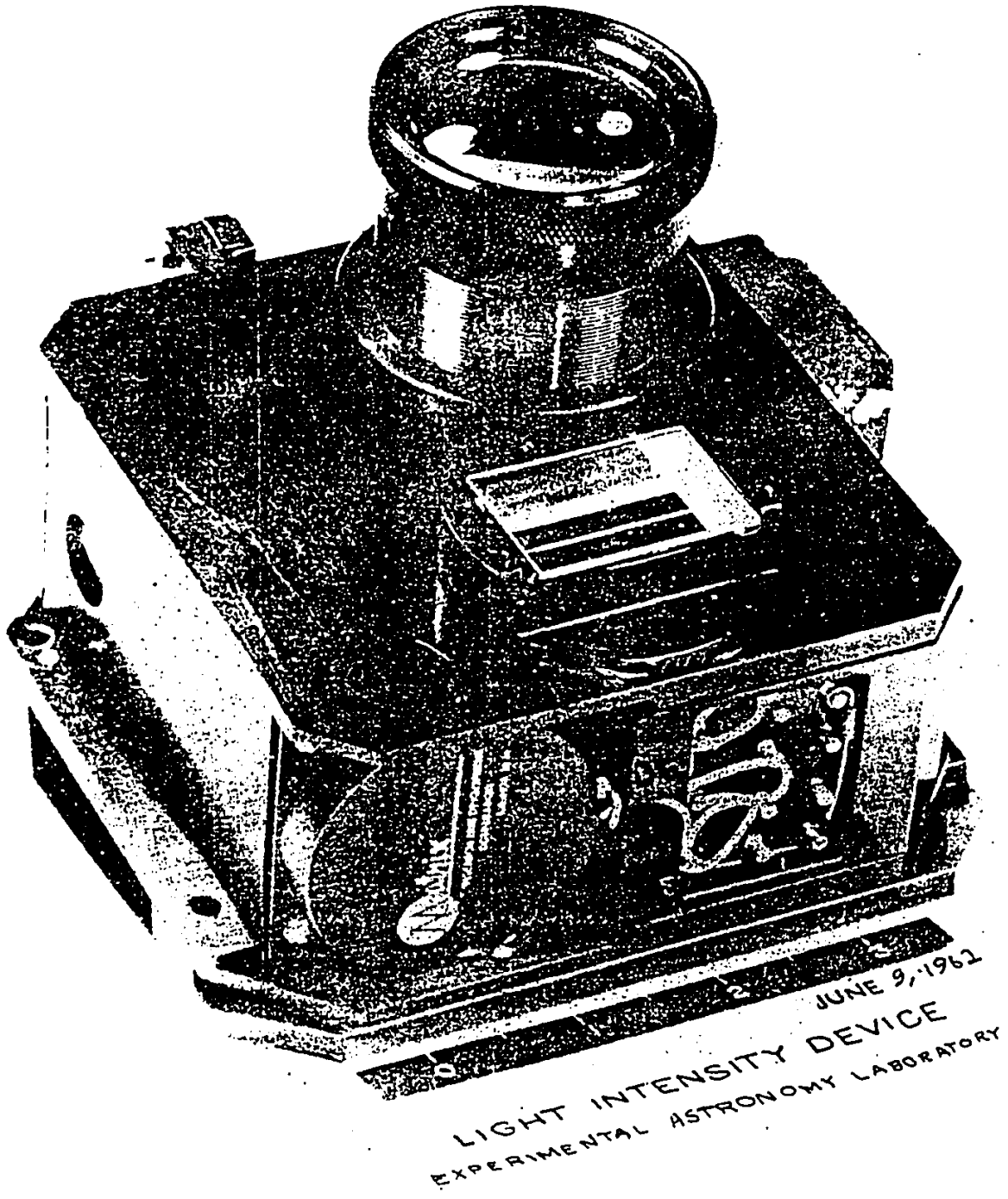

Figure 7

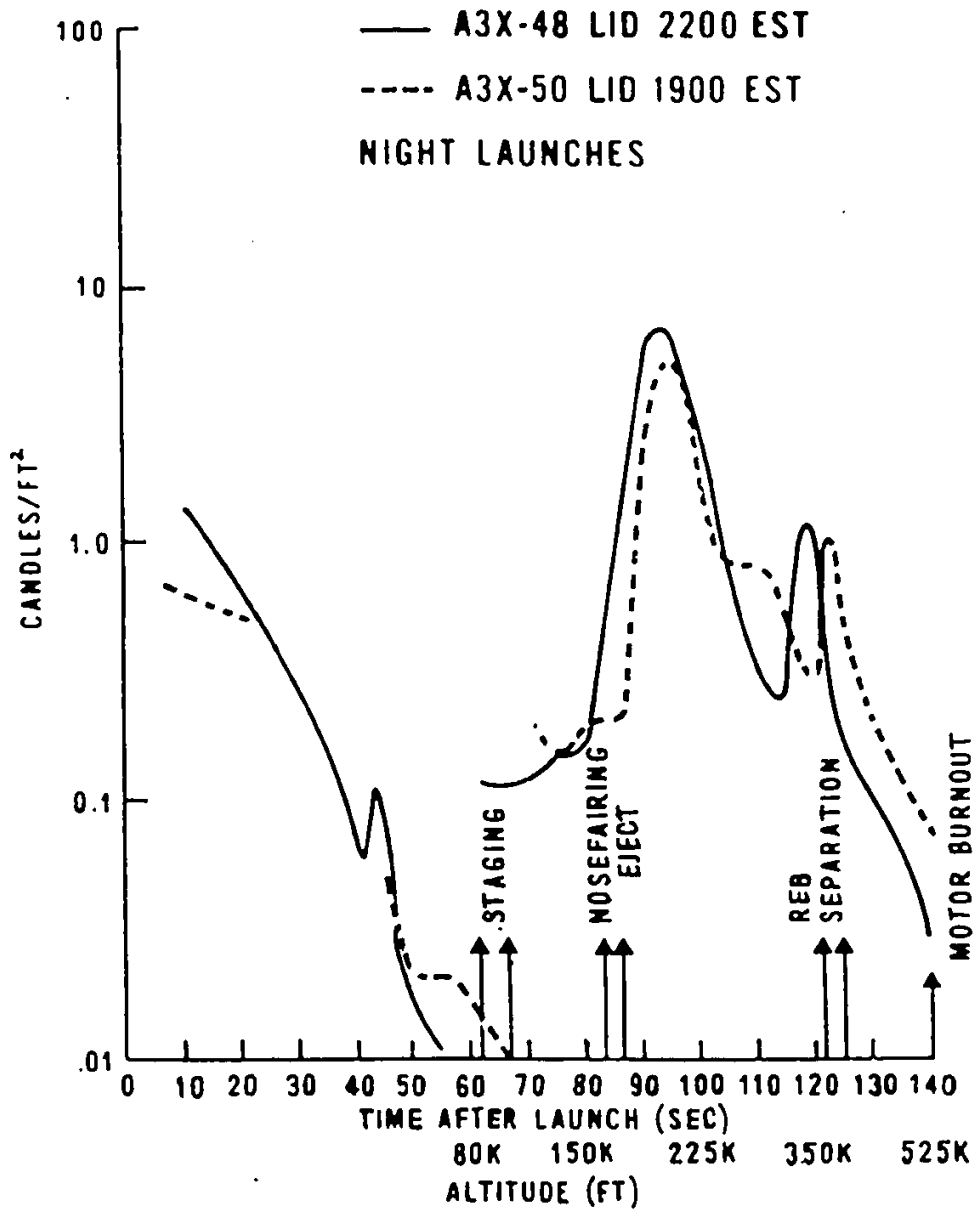

Figure 8

bations are an order of magnitude greater than they are at night.

"The SPOT has an open window which gives essentially the same information as the LID would have given. All the curves show the identical pattern for both flights, A3X-48 and 50, so whatever is happening happens all the time and is very consistent."

"The difference of magnitude between day and night suggests that there is some kind of ionizing effect," said Mr. Stevenson, "which in the night case is reflecting the motor and in the daytime is reflecting the motor plus the daylight."

"Some of the outstanding theories have to do with particles being up in the field of view," remarked Mr. Coleman, "either in the slip stream of the missile itself, or in the flow region under the shockwave."

"That theory is re-inforced by what happens at the re-entry body separation," said Mr. Stevenson. "This high level lasts from two to four seconds and the REB's have long gone in that time. Whatever is happening hangs around for a while."

"The spectral contents after staging of both A3X-48 and -50 were almost identical so figure 9 shows only the spectral content of the A3X-48, and is representative. Plotted on the graph is the absolute radiant energy versus the wave length in millimicrons. If you add a zero to the wave length numbers, you come up with angstroms. The spaces outlined indicate the total energy observed at a discrete point in time. The times chosen are immediately after staging at T plus 65, and the outline at that time shows the slope or the energy contained at those wave lengths. The next time chosen was just after nose fairing separation at T plus 85, and then at the peak of the hump at T plus 95, and after the hump has ended at T plus 110. The width of each data point defines the filter bandwidth. Except for the peaking around the 4300- and 5900-angstrom region, the data follows very closely the curve defined by a black body radiating at a color temperature of about 3200° K. We will see later that this spectral profile closely approxi-

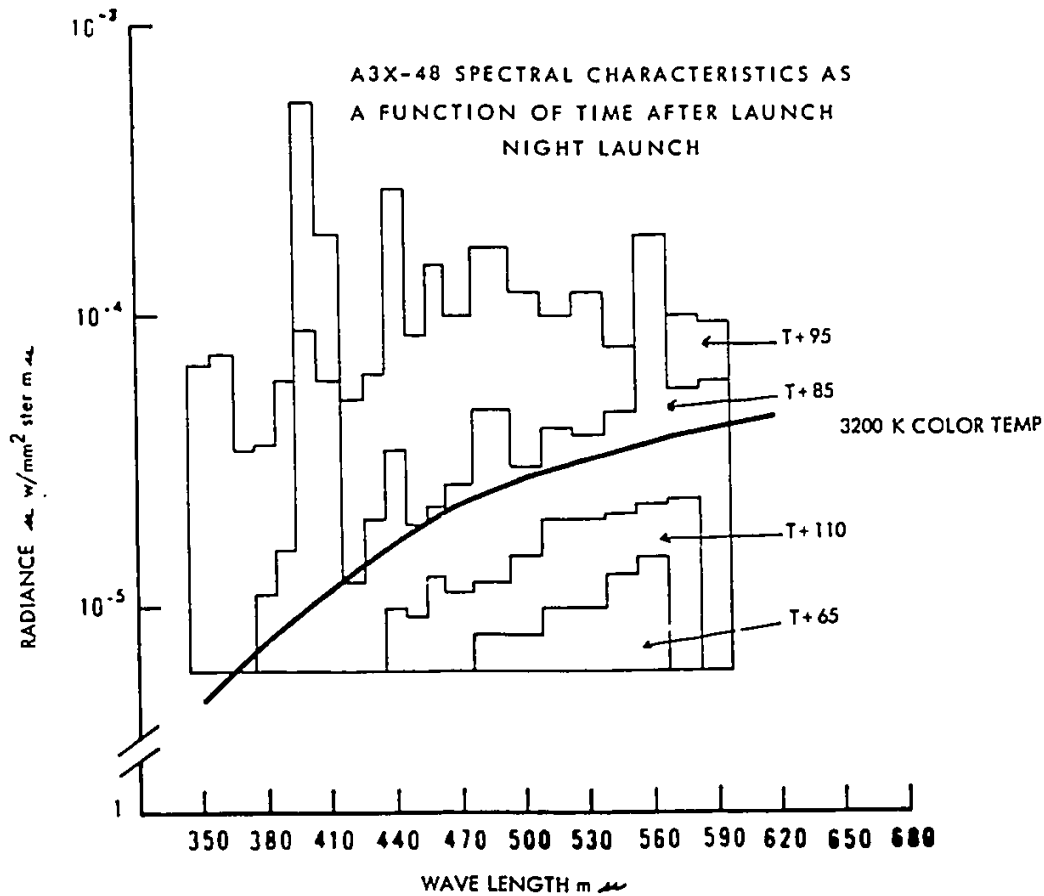

Figure 9

mates the spectral content of both the full-scale second stage motor which was fired at ABL, and second stage motor grains fired at simulated altitudes at NRL.

"The uneven energy levels at T plus 95 coincide with scintillations which were impressed on the peaks of the normally smooth oscillograph traces of the raw data. Since these scintillations occurred on both flights from approximately T plus 80 to T plus 110 at times of maximum light

levels, there is a suggestion of a flaking of larger particles passing through the field of view of SPOT and reflecting light generated by the missile plume.

"It is important that we understand what this curve means, because we are going to show two or three others of this same general nature. The results of the next flight are shown in figure 10. This is a daylight shot. The points of interest are the step increase of light level at staging, and the continued high level of approximately 500 candles per square foot through second-stage burnout. The difference in the absolute magnitude of the two instruments probably is the result of the geometry of the sun angle with respect to the look angles of the instruments, and to the surface of the windows. Sun angle to the tangent of the LID window was  $22^\circ$  and to the SPOT window,  $39^\circ$ . These curves correlate extremely well with the curves of the A3X-7 flight, previously shown in figure 3, which was approximately halfway between these two curves. So, here again the A3 deviates from the A2 in that it goes out steadily all the way to burn-out. This flight was at 11:30 A.M."

"There is a lack of coincidence of perturbations in the curves as a function of nose fairing and re-entry body separation, but it does not seem to be much except for the small slow rise which occurs after nose fairing separation."

"How much smoothing to these curves is done from your raw data? If you plot all your data points are they scattered around?" asked Mr. Parran.

"The raw data points would show a deviation of perhaps a factor of twenty percent which, since this is a log paper, would really be about a factor or two," replied Mr. Coleman. "About two inches would define the scattering pretty closely, but this is a definite trend. There is correlation because we had LID and SPOT on both flights and both showed exactly the same thing. The sun was on the window, it was at a slanting angle to it, of  $22^\circ$  in the case of the LID. However, it was

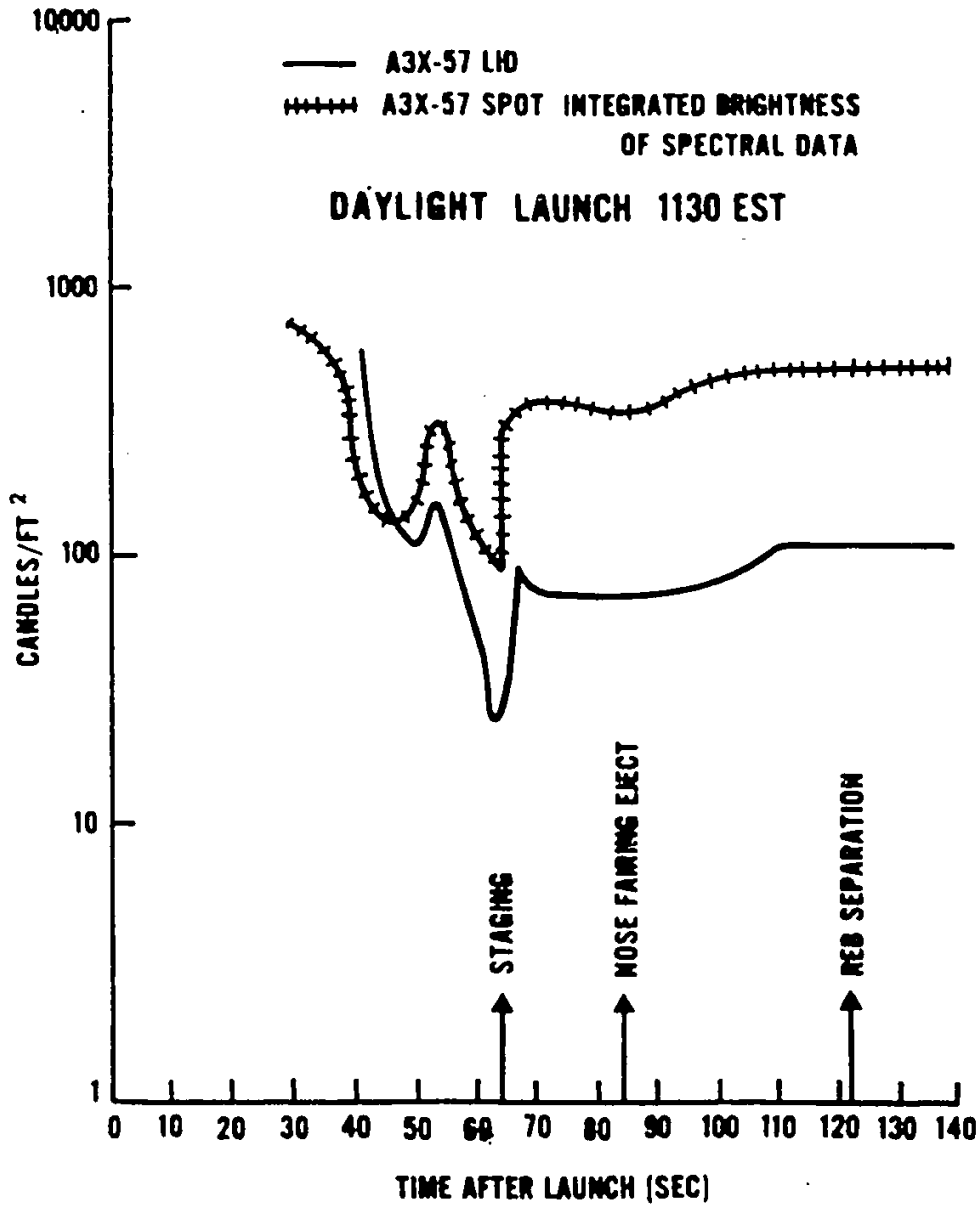

Figure 10





FIRE CONTROL AND GUIDANCE COMMITTEE DISCUSSION

well out of the actual field of view of the instruments. We had analyzed the window itself to show what the effect of scattering around the window would be. We checked it by putting a light through just the window at the various angles to calibrate it.

"We can now look at the spectral contents of this light that we saw at a particular point in time, as shown in figure 11. At T plus 30 we are approximately 25,000 feet up, where SPOT observed a spectrum roughly equivalent in slope to that of the sun. At T + 60, where the average background light had diminished and just before staging, a spectrum again was observed to have the same slope as the sun and likewise at T plus 70 shortly after staging. So, it is concluded that all the observed

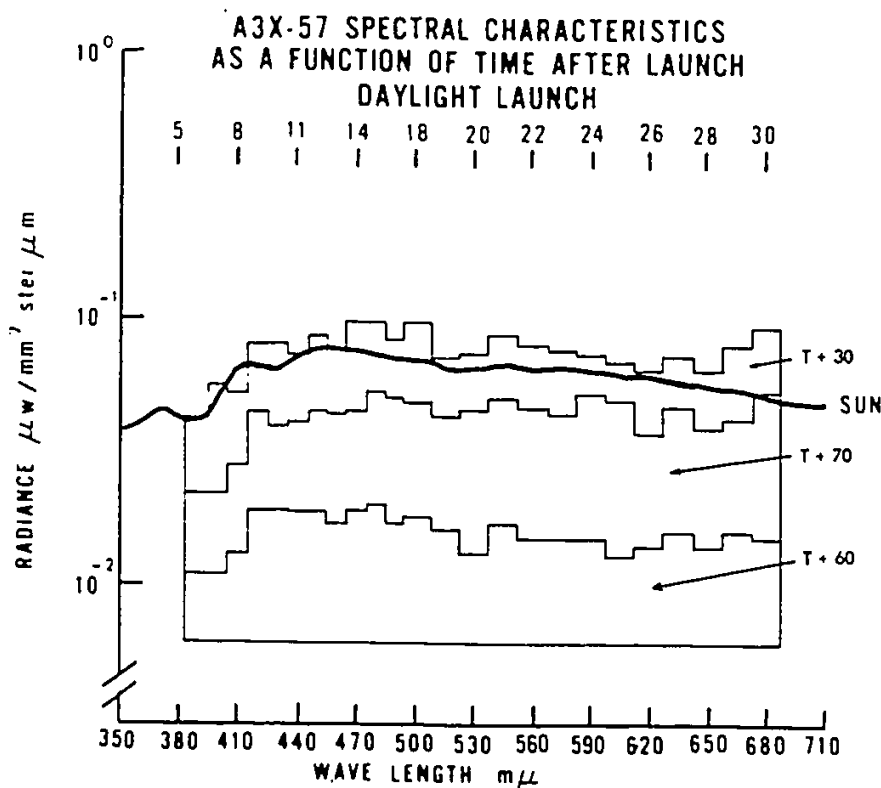

Figure 11

light had as its source the sun reflecting or scattering off particles in the field of view of the photometer.

"The reason I did not pick the same points — T plus 85 and T plus 95 — is that I plotted several other points for showing T, and they all indicated the same thing. They all have the profiles from T plus 30 to burnout and showed the same pattern you see here, so these are very representative.

"Because of the apparent dependence on the sun angle on A3X-57, the next experiment on A3X-58 shown in figure 12, was designed to guarantee that the windows and the line of sight be in the shade of the missile. This also meant that any scattering of the sun by particulate matter in the field of view of the instrumentation must be accomplished via secondary scattering or double reflectance around the missile. To achieve this, launch time was set at 7:30 A.M. The windows were thus about 180° around the missile from the sun. The results show the brightness coming steadily down with time, with only a slight perturbation at staging. The three curves indicate the correlation of three separate sources: the LID, the SPOT open window, and the integrated spectra from the SPOT.

"A missile malfunction occurred at about T plus 80 with immediate loss of data. This was unfortunate as all the unexpected phenomena begin to occur right after this time. There is a slight indication that the brightness is beginning to increase but that is about all one can say from this.

"The spectral content observed at periodic times has the same shape throughout powered flight, and is the spectral distribution characteristic of a dark blue sky. It is evident from the results shown in figure 13, that solar reflection from particles in the field of view of the instruments is not taking place, whereas the blue is the result of scattering from the solar source.

"Figure 14 illustrates the special spectral measurements made at the Allegheny Ballistic Laboratory on the full-scale POLARIS second-

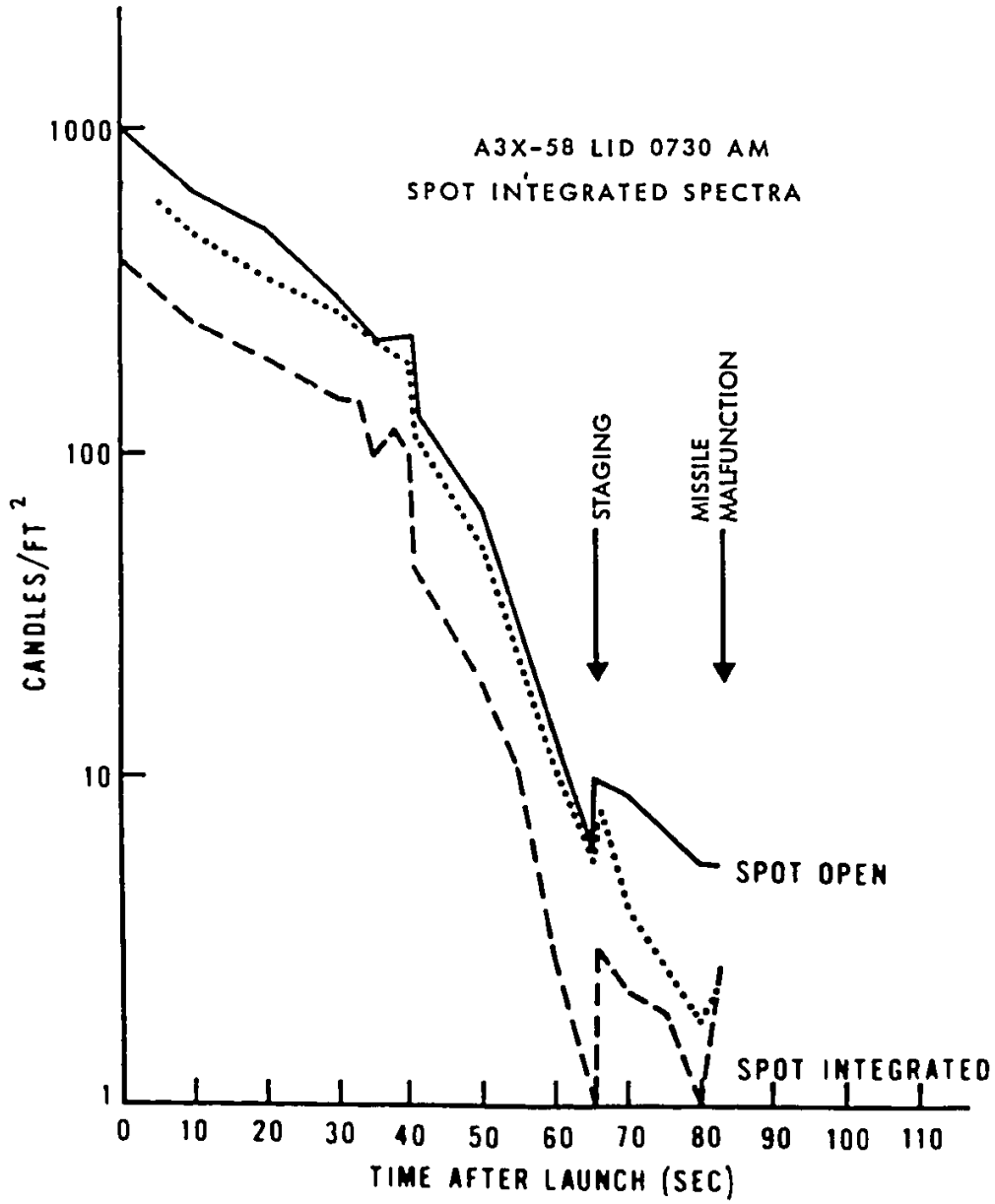

Figure 12

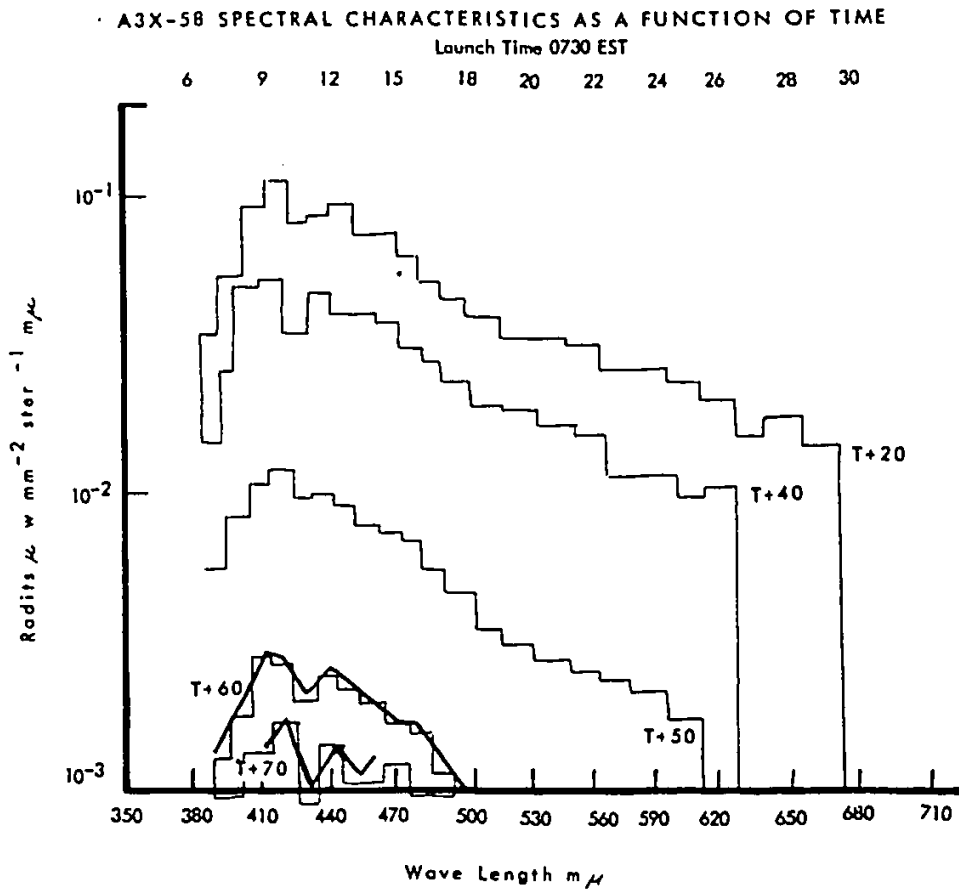

Figure 13

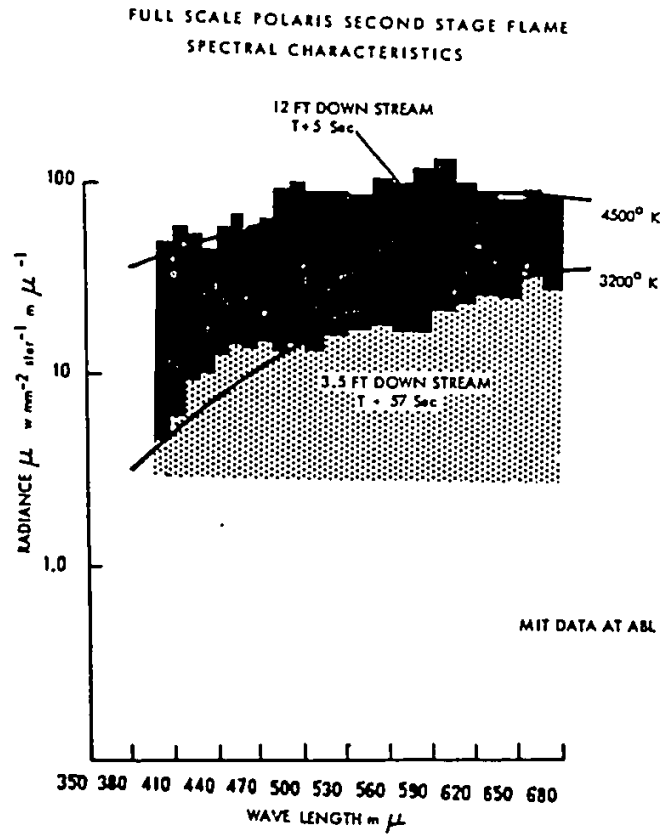

Figure 14

stage motors by MIT and NRL personnel. The intention was to correlate this with second-stage motor grain firings at sea level, and at simulated altitudes in the NRL altitude chamber. These firings would then be correlated with the flight test spectral measurements.

"The results of the ABL full-scale firing at sea-level are shown in figure 15. The two upper boundaries indicate the radiant energy on two different firings at different spots downstream from the nozzles. The two profiles are quite similar in slope; however, a best fit black body color temperature indicates slightly higher temperature for one finish. The important thing to be derived from this graph is that all the energy is contained in the continuum with no zones of absorption evident. A Hilger spectrograph did detect very weak lines of aluminum and sodium and weak bands of aluminum oxide superimposed on the continuum, but for the most part closely resembling the continuum. This was the actual A3 second stage motor.

"Experiments at NRL involved firing A3 second stage motor grains, weighing about five pounds and developing approximately 40 pounds of thrust. These were fired at sea level pressures and at simulated altitudes up to approximately 150,000 feet. The results, in figure 15, show that there is only a slight spectral shift between sea level and 100,000 feet and that most of the energy is contained in the continuum. The same weak line and band structure were seen as they were in the real motor. Furthermore, the slope at all altitudes closely resembles a blackbody at approximately 3200°K. Extremely good correlation exists among the motor grain flame, the actual second stage motor, and the spectrum seen on the night flights of A3X-48 and -50.

"It can therefore be stated with certainty that the source of light causing the A3X-48 and -50 humps is the second stage motor flame. The jump in absolute intensity of the light at staging is most likely due to the difference in proximity of the field of view of the second stage motor versus the first.

"It can also be stated with some certainty that the source of light in the A3X-57 daylight flight was the sun.

A3 MOTOR GRAIN SPECTRAL CHARACTERISTICS AT SEA LEVEL AND SIMULATED ALTITUDE

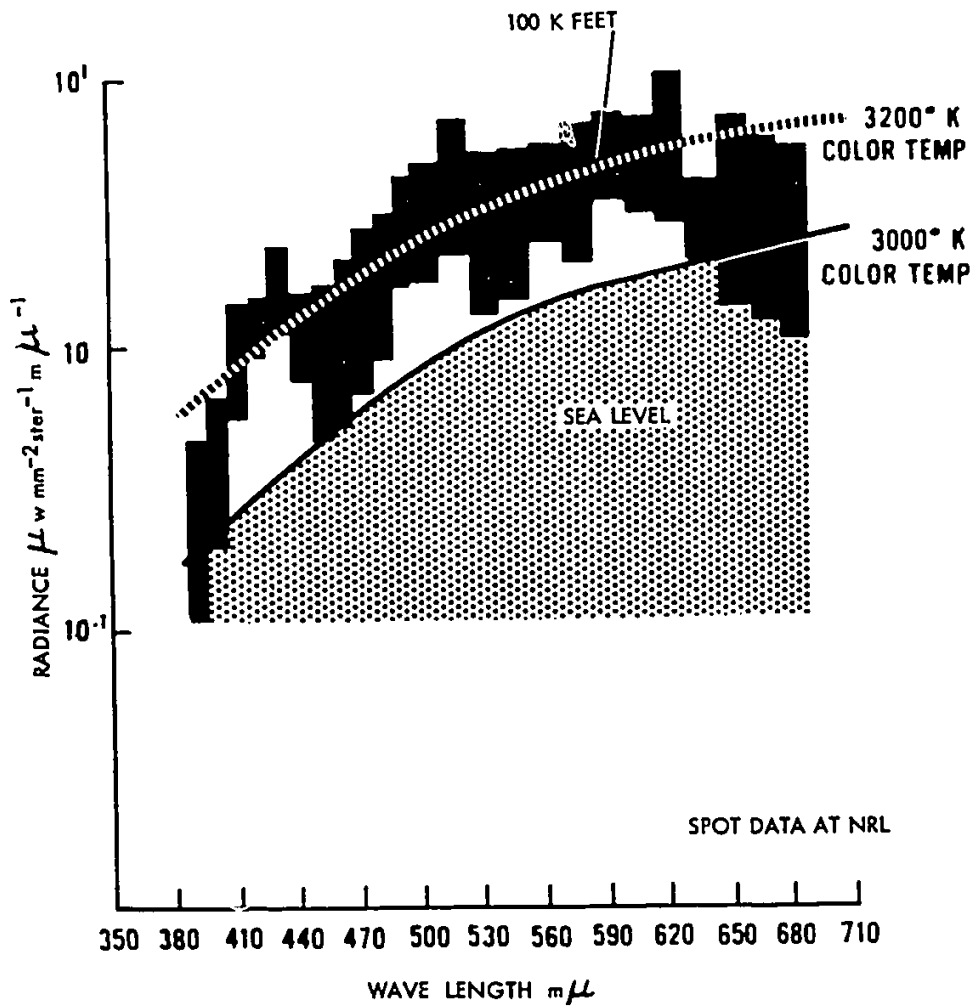

Figure 15

"An analysis of A2 and A3 windows with regard to light reflectance from the edges and supporting bracketry, or scattering from the molecular structure of the glass, has indicated conclusively that these are not the primary mechanisms. It has been vividly demonstrated that the field of view of both LID and SPOT is so sharp that the contribution of light just outside the field of view is down by six orders of magnitude. A specially designed sun shade was flown on each flight experiment to further limit the light source to that of the background space. The presence of a film or other material on the window in the field of view of the instruments will reflect any light source directly into the system. This kind of window fouling is under serious consideration as a prime mechanism.

"To check out theories regarding ablation and its contribution to the observed light levels, Lockheed conducted Phase III of this program for us. They looked into the vehicle surface temperature histories of both A2 and A3 missiles, and derived from this ablation mass flow rates as shown in figure 16. These curves indicate the predicted mass flow rates in pounds per second versus time of flight of each vehicle. Of particular interest is the fact that the rate of A3 materials is approximately two orders of magnitude greater than that from the A2. There is close correlation between the mass flow rate and the brightness profiles observed.

"The Lockheed study also included the possibilities of radiation from shock heated air; radiation from ablation products; and radiation from reaction between ablation products and shock heated air.

"Now, with regard to the shock heated air several molecular radiating systems were hypothesized. Based on assumptions of temperatures on the order of  $3000^{\circ}\text{K}$ , density ratios on the order of  $10^{-4}$ , and a high temperature air layer 90 centimeters thick, the brightness was calculated to be about 0.2 candle per square foot. At lower densities and temperatures the brightness is even smaller, which discredits this theory.



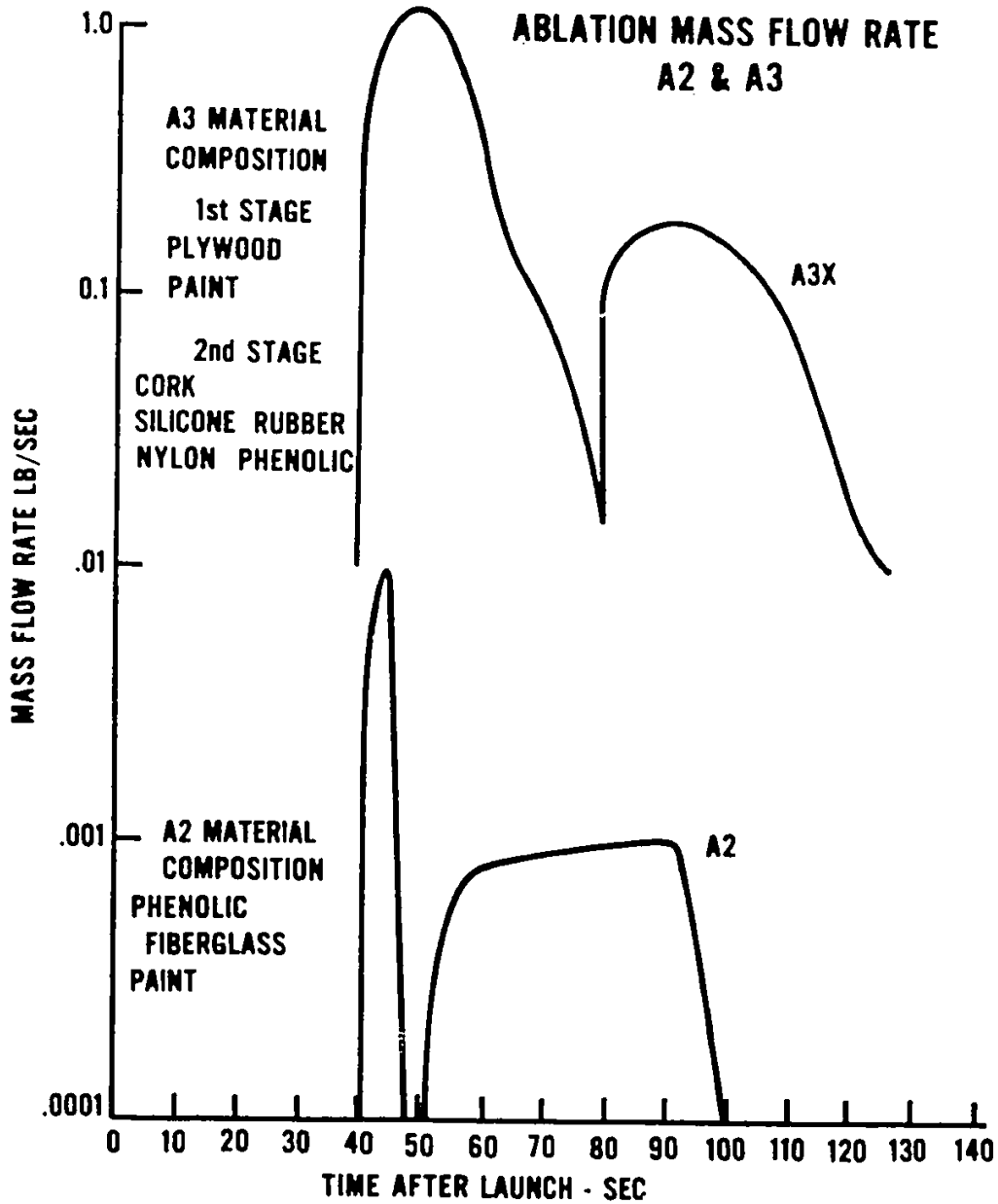

Figure 16

"It is difficult to predict the composition of the products of ablation of paints, corks, silicone, rubber, nylon phenolic and the like. The equilibrium compositions for pyroanalysis of nylon phenolic, for example, show numerous low molecular weight hydrocarbons. With all the assumptions and unknowns that went into this analysis, it is impossible to make a valid qualitative statement on the amount of radiation emitted from ablation products. It is felt that these mechanisms are not predominant causes of the brightness levels.

"The analytical study of the possibility of reflection of the motor plume off the shockwave has revealed that a brightness of about 10 to 14 candles per square foot would be required to achieve the observed brightness levels. Measurements of the brightness of the flame at ABL and NRL yielded brightnesses on the order of  $10^5$  and  $10^6$ . In addition, if this were the mechanism, the brightness profiles of night and day flights would be the same, but they are not. So, we conclude that this shockwave theory is not valid.

"In conclusion, there are two possible theories to explain the high light levels at altitudes of interest which have survived the critical test of analytical evaluation and experimental results.

"Although diligence was shown in cleaning the missile windows just before each launch, some people have brought up the possibility of fouling of the windows by ablation or other particles during flight. It has been demonstrated that a dirty window will reflect light directly into the optics provided an intense enough light source is available.

"It has also been shown that the sun by day and the missile flame by night are the primary light sources. The size and source of such particles are the important parameters and cannot be deduced from the data that we have so far.

"The second general theory postulates the flow of ablation particles consisting mostly of low molecular weight hydrocarbons from the nose sections. Their presence in the slip stream or in the separated flow

[REDACTED]

FIRE CONTROL AND GUIDANCE COMMITTEE DISCUSSION

region would provide an excellent scattering medium for any light source. The difference in the A2 and A3 light intensity profiles may be explained by the large difference in predicted particle flow rate of the two vehicles. The reason for these differences concerns the nose cone geometry of each.

"From this experimental program the results have shown that star acquisition is possible at night with no obvious problem. However, acquisition in most daylight hours is very marginal for the A2, and bordering on impossible for the A3 using star detecting devices which can discriminate through a 100 candles per square foot background brightness.

"This concludes the data that we have gained to date on our spectral measurements."

"Did you consider at all the possibility that an out-gasing effect as a function of altitude could be occurring from the missile itself?" asked Mr. Stevenson.

Mr. Coleman said that they had not considered this. Captain Sanger remarked that he had heard the Air Force was considering some flights as a follow-on to these.

"When I was out there about two weeks ago they indicated that they would like to fly three A1's," remarked Mr. Coleman. "These A1's would be fully instrumented with SPOT's using various configurations, with all possible mechanisms involved. They were going to shine flashing lights out to see if there were particles in the field of view.

Captain O'Neil stated that he was glad they had not gone ahead on the star field scanner, and would want to put more money into solving these problems before they did. He then recessed the meeting for 10 minutes.

SYSTEMS APPRAISAL COMMITTEE  
REPORT DISCUSSION

"I must first apologize for not having any copies of my report ready for distribution before this meeting," began Dr. Craven, "but it was not possible to do so. After I finish my presentation, Mr. Robert Miller will give you a more detailed presentation of one phase of my report.

"With the start of the DASO program this month, I feel that the POLARIS program has reached a major milestone. If the Russians do not do anything to counter the threat posed by the POLARIS missile, then our responsibility in developing and producing a deterrent weapons system is finished. We will not need the B3 nor any other follow-on program. The DASO's are themselves an indication that we have reached the end of our development program, and this is a major milestone indeed.

"But the Russians will and are doing things to confront and counter the threat posed by our program. We must accept this fact; we must identify the tasks that face us; we must choose from among the alternatives confronting us; and we must do these things in full cognizance of what the Russians are doing and will have to do. This fact was emphasized for us recently in a letter from DDR&E in which Dr. Brown made an important definition, as follows:

Survivability  
Reliability  
+ Penetrability  

---

SYSTEM DEPENDABILITY

Our work in the design and development of our systems has reflected a constant concern with a high level of dependability. Of the three com-

ponents that make up dependability, we can assure reliability ourselves by our own best efforts; our ability to assure survival and penetration depends in a large part upon what the Russians do.

"Our knowledge of what the Russians will do is limited but we do know that they can devote tremendous resources toward solving their problem of lessening our abilities to survive and to penetrate onto targets. This presents us with something of a dilemma in those choices we make to prevent the decay of our weapon system dependability, for we must anticipate Russian events that will in turn change our chances of survival and penetration.

"If we are to maintain dependability then we must put forth major efforts to secure and assure for ourselves each of those three components. As we see it, Survivability can be divided into two major effort areas:

1. Survivability of command and control communications.
2. Survivability of the SSB(N) in a hostile environment.

Mr. Miller will talk at some length on the second topic. The first item, communications, has always been a great source of concern and difficulty to us. Ultimately, command and control communications to any sea-based system must lead back to the Continental United States, and finally back to a single individual, the President or his legal successor. Thus, for command and control communications to survive, we require the survival of some complex of our society which can identify and accept the President or his legal successor, and which can transmit to him the prerequisites of command. A deterrent system such as ours must be predicated on the basis that this central complex will continue to exist always and will be able to maintain rapid and effective communication with the deterrent weapons system relative to any developing political crisis. These features are important design constraints on such a communication system, because we must be able to prove the ability to communicate in a survivable mode in a time span which may be very short in comparison to the span of the crisis which calls for use of the

SYSTEMS APPRAISAL COMMITTEE DISCUSSION

deterrent. The identification and development of systems to fulfill these requirements is the responsibility of the Special Projects Office.

"We have heard a number of presentations on communications that support our previous analysis in indicating that the present communication system performs well in a cold war environment, and will perform well in an environment where the antagonist elects against interference. Surprisingly enough, in looking at some of the war games that have been run, we have found many situations in which the antagonist elects not to interfere with the communications to the deterrent because he feels that there is a more responsible attitude with the central command authority than there would be in the hands of a less controllable environment. We cannot rely on this attitude, however, so we have to examine ELF, VLF, acoustics, Bagatelle, VLF MUX, NOMAD, TACAMO and others as potential candidates for a survivable system. Regardless of the final choice of systems, it is a fair conclusion that a task that we must do is to develop our command system within a timescale that precludes a buildup of any countermeasure system able to destroy the creditability of the present command and control system. We feel this development is a necessity

"Another important problem which has been given less attention is the ship-to-shore system, although the reason we have given it less attention is the fact that only marginal utility can be drawn from the information generated by reply to receipt of a message of deployment, or of any other purpose.

"We have always said there are many possible situations in which the Executive will require communication from each submarine on patrol. For example, in one of the war games being played by MIT on POLARIS communications, a scenario is set up in which a POLARIS submarine does not return from patrol for 15 days. Every time this game is played, the U. S. team immediately calls for a communication from each POLARIS submarine on patrol to determine that each is indeed in existence. That aspect of a deterrent system is such that any time a question about the survivability of the deterrent comes up, it will be hard to

stop the Executive from calling upon the ships to report in. Thus, the need for improving the ship-to-shore communications is another task which we need to pursue in the near future.

"We have been talking in a sense about tasks that face the Special Projects Office. My committee has defined five such tasks and each definition was arrived at by individual decision of the various members rather than by any committee group action; in each case separate concurrence was obtained from each member. Thus far I have mentioned two tasks:

- (1) Development of an assured survivable command and control communications system, and to do so within a time-scale that will preclude any successful enemy countermeasure system able to destroy the credibility of the present command and control system.
- (2) Development of an improved and survivable ship-to-shore communications system.

These first two of the five tasks deal with communications; the third task deals with defense of the submarine, which Mr. Miller will discuss at some length. Threats against the submarine itself, while not too well defined, must not be ignored. Some time ago, we did a study which indicated that not until after tremendous advancements have been accomplished in ASW would we really have to give serious concern to the problem of SSB(N) vulnerability. The results of that study have generally qualified our thinking about threats to the submarine and caused us to minimize them.

"Two years ago, we suggested that NOL perform a new study which Mr. Miller worked on as the NOL-SP liaison man. This study was quite extensive and quite detailed; along with its conclusions, it carried a proposal for a development program on a new defensive weapons suit. The basic conclusion was simply that the cold war tactics of tracking and trailing lie within reasonable probability today if the SSB(N) defensive suit is not modified.

SYSTEMS APPRAISAL COMMITTEE DISCUSSION

"One of the SSB(N) skippers reported that in one patrol in the Mediterranean he had over 2000 sonar contacts. Unless the submarine has the ability and equipment to sort these contacts out and classify them carefully, he would have a great deal of trouble ever finding out whether or not he was being tracked and trailed. This can be part of the daily environment of a submarine in a cold-war situation.

"The recently completed study identifies the advantages which accrue to the quiet, slow-moving, evasive submarine that is equipped with a sonar suit that maximizes passive listening capabilities. This is how we must think in terms of equipment for SSB(N)'s in future, for the passive listening ability together with an ability to measure and use the immediate environment and an ability to use adequate decoys will permit the SSB(N) to render the threat of enemy ASW unattractive in terms of economics for the Russians. The cost and risks of their effort will not be worth the results they can expect from it. In presuming this threat, incidentally, we are presuming a truly major effort on the part of the Russians and we should hope that we may receive some intelligence about their efforts and particularly whether these efforts will lead to some increase of threat to the SSB(N). Thus we can identify the third task:

- (3) The identification and development of changes in the defensive suit of the SSB(N). These changes must be accomplished within a time-scale that will keep ahead of any foreseeable anti-SSB(N) threats.

Here we must bear in mind that our ability to modify the SSB(N) to meet these threats is itself conditioned by the overhaul program cycle.

"The threat to the submarine, however, is a threat to but one U. S. strategic deterrent system. The Anti-Ballistic Missile System constitutes a threat to all and thus becomes an attractive thing for the USSR to look at. The A3 warhead concept was an early realization of the need for penetration capability, and in this I think we took a substantial and an important lead which has been supplemented by a penetration aids package. These developments appear to give us a satisfactory lead



in maintaining penetrability, but the Soviet emphasis on defensive systems and man's ingenuity in design of intercept systems, together with the fact that a ballistic missile defense constitutes a common defense against our total strategic threat, point only to one conclusion: Our continuing efforts in penetration are mandatory.

"As we look into this problem, any presumption that our decoys are inherently non-discriminable — which many of us thought — is quickly dissipated by even a cursory inspection of the radar records from Kwajalein and Trinidad. Only the most sanguine would ever say that the present decoys constitute a major addition to the penetration package; the importance of multiple warheads, active jammers and chaff is thus reinforced and the importance of the B3 with its increased payload is again strongly emphasized by the results of these tests. Thus our fourth task:

- (4) The identification and development of penetration aids and techniques which will assure a continued high level of penetrability in the face of a developing threat.

"These four tasks — two in communications, one in defensive weapons, and one in penetration — must be carried on. The extent to which we carry them forward is dependent directly on the progress of the USSR and the Communist Bloc. The fifth task required to maintain dependability confronts us right now in the reliability and accuracy of the A3 missile system.

"I think Captain Christman's presentation today was ample evidence of the difficulties we are going to foresee. Indicators already exist that the in-flight reliability of the A3 may be significantly below that of the A2 missile. If we had pressed Captain Christman to give us, instead of estimates, the figures that are coming out of some of the tests in advance, we could take a conservative viewpoint and still reinforce any projection we may make of the A3 in the future. In their entirety, these figures do not suggest high reliability. The DASO tests should provide a steadily increasing measure of this and, in particular, well identify the chief contributors to the reliability figure. Once flaws are iden-

SYSTEMS APPRAISAL COMMITTEE DISCUSSION

tified, the procedures which we are allowed to use to correct the deficiency are greatly constrained.

"Design changes without full qualification cannot be tolerated, particularly if this reliability factor is a result of the large number of items which occur rarely. The fact is we always go through a frustrating problem as we make a change because we cannot really test whether the change is an improvement or not until we have gone through a large number of tests. In other words, we will not be able to improve the reliability without qualification, and our primary approach must be based on what we see in some of these tests, and the identification of the manufacturing and inspection procedures which are employed in order to establish the causal relationship between these techniques and in-flight success and failure.

"We have, then, a very difficult task confronting us now and in the future; we must approach the problem of measurement of A3 missile CEP and the contributors thereto. If we approach this in only slightly better shape than that in which we approached the problem of A1, we may not be in as good shape. The inability to accurately measure separation velocity is still with us. What ability we have to infer this quantity from the pattern of re-entry body dispersion is largely a function of our knowledge of winds at the target, the mode of re-entry body spin and the effective determining of relative position by the use of bottom mounted hydrophones, using SOSUS-type arrays.

"I think we must carefully review this program to make sure that we do indeed use these SOSUS-type nets to the best of our ability, particularly in reference to relative re-entry body spacing, so that we can get the most out of the DASO shots, in terms of our CEP.

"This is the burden of our report."

Dr. Barrow wished to relate these remarks about communications with the review of communication efforts recently given by Captain Dudley in which a number of systems were brought to the point of operability

only to be jettisoned by CNO. Dr. Barrow pointed out a seeming disparity between what SP feels is essential and what the Navy is willing to buy.

"In all fairness," replied Dr. Craven, "and particularly in fairness to CNO, I do not think that we have been able to fully establish, on a national level, the quantitative features that survivable communications in a deterrent system will require. This matter is being thoroughly looked into now by a joint committee and the central problem for this group lies in their contemplation of the post-strike environment and the decision on whether there is a necessity of communicating with the SSB(N) in a short period of time or whether we can be satisfied with the fact that communication will inevitably, eventually be successfully established.

"The committee reviewed all the evidence possible and decided that one of the powers that belong to the President is the ability to establish communication with the FBM submarines. Regardless of the other factors, anything less than the ability to communicate with reasonable speed would be unsatisfactory in terms of the position of the Chief Executive.

"Indeed, it was a conclusion of this group, after looking at all of the evidence available drawn by inference from what emanates from the Executive, the Secretary of State, and from the Department of Defense, that we need to be able to communicate in a survival mode to the POLARIS submarines during the time period, which would be short, that we want also to communicate with the enemy to bring the hostilities to a successful termination. This factor was indeed the relative time measure.

"The Chief Executive always should have the ability to demonstrate his control of his forces particularly when he wants to bring the hostilities to a successful conclusion on his own terms. To demonstrate this capability, one cannot launch a message into the blue and wait for a period of time from eight to twelve to sixteen hours before it arrives. Too much can happen in the interim.

"The extent to which the conclusion of this group is concurred in by OSD may represent one of the first attempts to quantify this thing. If OSD agrees, it will help the Navy tremendously in the dilemma that it is facing now. It is indeed true that the Executive, in contemplation, really may have reason to question whether we can stand such an 8- or 10-hour delay in the post-strike environment. We have a satisfactory system which can get a message there in a post-strike environment in 10 to 12 hours with a high degree of reliability one way or the other. Does that answer your question or does it lead to it?

"You answer with much detail and little generality," replied Dr. Barrow. "But should we start another communications development program according to this quantification, will the committee's attitudes mean anything in terms of adoption of the system developed?"

"To be general for a moment," replied Dr. Craven, "if we in the Navy can force OSD to take a quantitative position, we will be able to move off-center ourselves; if we cannot force them to take such a position, then we stay on dead center, if only because we are dealing with an indeterminate problem. We feel that OSD is ready to move off center with this problem; we think that they must move."

"Have you considered the risk of the submarine exposing itself in this ship-to-shore communication?" asked Dr. Barrow. "Exposure seems like an inevitable risk in attempting communication."

"We plan to develop this system to the extent where it would not have to be used except in the most critical circumstances," replied Dr. Craven. "The submarine would certainly never be exposed to handle trivial message traffic. Conditions would have to warrant the risk for such a system would ever be used."

With no further questions, Dr. Craven introduced Mr. Robert Miller for his report on submarine defense systems.

SYSTEMS APPRAISAL COMMITTEE DISCUSSION

Presentation Given By Mr. R. Miller

"Last June," began Mr. Miller, "the Special Projects Office was given a TSOR -- partly shown in figure 1 -- by the Chief of Naval Operations, that called for a study of an integrated SSB(N) defense system. Figure 2 is

TENTATIVE SPECIFIC OPERATIONAL REQUIREMENT  
(W13-02T) -- DATED 3 JUNE 1963

"REQUIRED CAPABILITY IS TO MAXIMIZE SURVIVABILITY OF THE SSB(N) UNDER CONDITIONS OF COLD AND LIMITED WAR AS WELL AS ITS ABILITY TO CARRY OUT ITS PRIMARY DETERRENT MISSION IN THE FACE OF ENEMY OPPOSITION."

"TO ANTICIPATE ENEMY ADVANCES IN ASW AND REDUCE ANY ENEMY ADVANTAGE RESULTING FROM THE REPETITIVE NATURE OF SSB(N) PATROL TACTICS AND CERTAIN LIMITATIONS IN THE CHOICE OF SSB(N) COURSE, DEPTH, AND SPEED NECESSITATED BY THE REQUIREMENTS FOR CONTINUOUS COMMUNICATION COVERAGE AND LAUNCH READINESS, IT IS NECESSARY TO DEVELOP AN INTEGRATED DEFENSIVE SYSTEM TAILORED TO THESE SPECIFIC AND UNIQUE SSB(N) REQUIREMENTS."

Figure 1

a quotation from the memo which Dr. Craven referred to as coming from Dr. Brown's office on this subject of dependability and the three ingredients which John addressed. I will address the survivability factor in this equation. Figure 3 gives the membership of the Steering Group and

MEMO FROM DR. BROWN TO DR. WAKELIN  
DATED 19 FEBRUARY 1964

"BEYOND THE IMMEDIATE JOBS OF GETTING THE A-3 MISSILE OPERATIONAL AND CONTINUING SYSTEMS TEST AND EVALUATION, OUR EMPHASIS MUST BE TO MAINTAIN THE CURRENT HIGH DEGREE OF FBM SYSTEM DEPENDABILITY IN SPITE OF ANY LIKELY FUTURE COUNTERMEASURES THAT THE ENEMY MAY TAKE AGAINST IT. DEFINING "DEPENDABILITY" TO BE THE PRODUCT OF "SURVIVABILITY", "RELIABILITY" AND "PENETRABILITY", I AM HIGHLIGHTING THE FIRST AND LAST AS FACTORS WHICH MAY BE DEGRADED BY ENEMY COUNTERMEASURES AND ON WHICH CONTINUING RDT&E MUST BE FOCUSED."

"I REQUEST THAT YOU PREPARE ALTERNATIVE PLANS TO INCREASE RDT&E EMPHASIS ON THE ABOVE AREAS. THIS SHOULD BE DONE BEFORE FY 1965 APPORTIONMENT, AND STAFF DISCUSSIONS OF THESE ALTERNATIVES ARE DESIRABLE AT THE EARLIEST PRACTICABLE DATE."

Figure 2

INTEGRATED SSB(N) DEFENSE SYSTEM  
TSOR W13-02T  
STEERING GROUP

Rear Admiral L. Smith, SP-20, Chairman  
Rear Admiral J. A. Brown, BuShips  
Captain J. M. Barrett, SP-11  
Captain R. H. Gallemore, COMSUBLANT  
Captain F. A. Andrews, COMSUBDEVGRUTWO  
Captain A. W. Newlon, BuWeps  
Captain R. B. Gustafson, CNO  
Commander J. B. Padgett, DEPCOMSUBLANT  
Dr. J. P. Craven, SP-001  
Mr. R. J. Miller, SP-2031, Executive Member

WORKING GROUP

Mr. R. J. Miller, SP-2031, Chairman  
Commander S. T. Ebel, BuShips  
Commander D. Packer, BuWeps  
Commander J. B. Davidson, QNR  
Commander J. B. Hansen, SP-1141  
Mr. J. L. Carroll, OCEANO  
Mr. J. F. Cotton, ORI  
Mr. J. Kucharski, HRC

Figure 3

the Working Group, which was formed to implement the paper; the study requirements of this TSOR are initiated here. The Steering Group was chaired by Admiral Smith. The major participating activities throughout the process of this study are given in figure 4.

MAJOR PARTICIPATING ACTIVITIES

Naval Ordnance Laboratory	Naval Electronics Laboratory
Wagner Associates	Naval Underwater Ordnance Laboratory
Operations Research Incorporated	Naval Air Development Center
Howard Research Incorporated	Naval Oceanographic Office
Marine Physical Laboratory (Scripps)	Electric Boat Company

Figure 4

## SYSTEMS APPRAISAL COMMITTEE DISCUSSION

"When we initiated the study effort, we established the goals listed in figure 5. I believe the first goal is a self-evident attempt to maintain the invulnerability of the total force throughout its lifetime. The second goal is equally self-evident: to promote research and development programs which are responsive to the peculiar mission and needs of the SSB(N) force. The third goal is to establish objectives for R&D programs consistent with the rigid overhaul schedules; and, finally, to attempt to integrate the study and the development of defensive equipments.

### GOALS

- I. Maintain SSB(N) Force Invulnerability.
- II. Promote R&D Programs Responsive to Needs of the SSB(N) Force.
- III. Establish Objectives for R&D Programs Associated with Overhaul Schedules.
- IV. Provide Effective Defense System with Maximum Integration of Internal and External Equipments.

Figure 5

"We say 'integration' because if all the programs for towed systems were actually developed that have been proposed and are now in some stage of development, I am afraid that our submarines might eventually look like figure 6.

"Figure 7 shows the approach we have adopted for development of the PTA. This is our attempt to examine the key problems which designers have faced in the development of anti-ASW equipment, of sonar weapons, and other defensive equipment. In this approach we have tried to do a thorough operations analysis of the mission and needs of the SSB(N), and in that analysis to make a careful evaluation of the threat which the SSB(N) would face through the period of its lifetime.

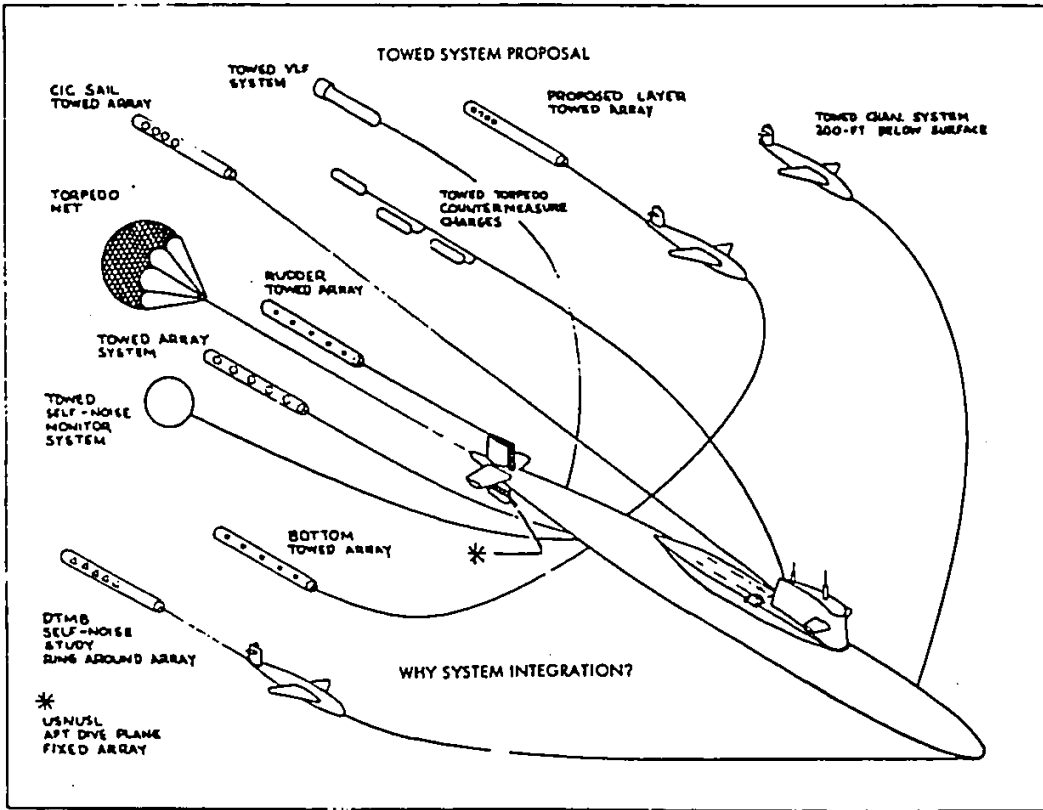

Figure 6

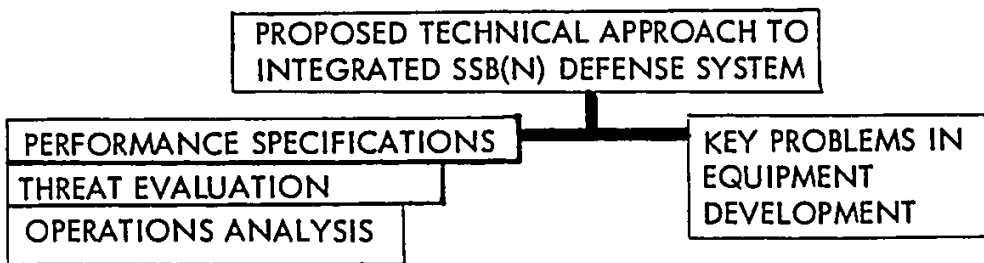

Figure 7



SYSTEMS APPRAISAL COMMITTEE DISCUSSION

"From these analytical studies, we would then develop performance specifications which were uniquely suited to the needs of the SSB(N) force and marry these specifications to the key problems. We would then attempt to develop our proposed technical approach.

"The documents which emerged as a result of this study, shown in figures 8 and 9, make up a multi-volume set which certainly passes the weight test and volume test if nothing else. The first document is the basic Proposed Technical Approach itself. The format which DOD prescribes for a PTA does not permit development of a justification in the depth that we felt was necessary to support this system, so we decided to incorporate a series of annexes. Annex A is the threat evaluation, and Dr. Craven has previously given you a good, brief summary of that. Annex B is a description of the system which we are proposing. Annex C is a compilation of the supporting operations analyses for this defense system, and you can run briefly through the list of the included analyses to get an idea of the thoroughness with which we tackled this job. The major portions of these analyses were directed by Mr. Cotton who is here today to help me answer your questions. Annex D is a compilation of supporting systems analyses, and Annex E contains additional independent reports of which the last three were forerunners of this study effort.

"Then in figure 10 we have the recommendations which come out of this study. We have listed the hardware items which the PTA recommends for development for the SSB(N). I will discuss each one of these in some detail. In addition to the items of hardware, we are recommending that certain research and development programs, figure 11, be initiated for the SSB(N) defense, and I will also go into this in some detail.

"Before these details, let us briefly consider some of the results of the studies in Annex C, the operational analyses. We attempted, in figure 12, to categorize the threats which the SSB(N) faced throughout its lifetime. Within the context of these categories we approached our threat evaluation. The basic study in these analyses consisted of coming up with the effectiveness of an evasive mode of patrol on the part of the

**PROPOSED TECHNICAL APPROACH  
FOR AN  
INTEGRATED SSBN DEFENSE SYSTEM**

**Basic Proposed Technical Approach**

**ANNEX A**

**Threat Evaluation**

**ANNEX B**

**System Description**

**ANNEX C**

**Supporting Operations Analysis**

- I. Coordinated Active Search
- II. Conventional Submarine Search
- III. The General Effect of Other Passive Detectors on the Advantage of Evasion
- IV. Aircraft-Sonobuoy Sweep Rates
- V. One Aspect of the Effectiveness of Wake Detection for Localizing SSBNs.
- VI. Effectiveness of a Postulated Tracking Force
- VII. Weapon Delivery Requirements
- VIII. Proposed Study Approach to SSBN Countermeasure Applications
- IX. Analysis of SUBROC as an SSBN Defensive Weapon

Figure 8

SYSTEMS APPRAISAL COMMITTEE DISCUSSION

ANNEX D

Supporting Systems Analysis

- I. DIMUS SYSTEM PERFORMANCE CALCULATIONS
- II. BQR-7 SYSTEM PERFORMANCE CALCULATIONS
- III. REVIEW OF MAJOR PROBLEM AREAS IN COUNTERMEASURE DEVELOPMENT
- IV. REVIEW OF MAJOR PROBLEM AREAS IN TORPEDO DEVELOPMENT AND UTILIZATION
- V. STUDY OF AVAILABLE SPACE FOR DECOY LAUNCHERS
- VI. LAUNCHING METHODS FOR EXPENDABLE BATHYTHERMOGRAPHS
- VII. CONTROLLED POSITION TOWED ARRAY
- VIII. WHISPER POTENTIAL FOR THE SSBN
- IX. REVIEW OF HARBOR DEFENSE EFFORTS
- X. DEFENSIVE DISPLAY SYSTEM

ANNEX E

Additional Supporting Analysis

- I. SSBN DEFENSIVE COUNTERMEASURES (COUNTERING TORPEDOES AND BREAKING TRACK)
- II. TECHNICAL CONSIDERATIONS AND TRADE-OFFS IN DESIGN OF ANTI-SURFACE SHIP TORPEDOES
- III. PRESENTATION REPORT ON A STUDY OF FBM SYSTEM VULNERABILITY TO NUCLEAR DETONATIONS
- IV. A COMPARATIVE ANALYSIS OF PASSIVE SONAR SYSTEMS IN A PURE EVASIVE STRATEGY
- V. FBM DEFENSIVE ARMAMENT, PART III, PROBABILISTIC PASSIVE SEARCH
- VI. FBM DEFENSIVE ARMAMENT, PART VIII ENCOUNTER RANGE DISTRIBUTIONS

Figure 9

INTEGRATED SSBN DEFENSE SYSTEM

Prototype Equipment Development Recommendations

I. SONAR - PHASE I

VOLUMETRIC ARRAY  
TOWED ARRAY  
PASSIVE FIRE CONTROL  
ACTIVE FIRE CONTROL  
INTERCEPT RECEIVER  
INTEGRATED SONAR DISPLAY

II. COUNTERMEASURES

A. AVOIDANCE AIDS

1. EXPENDABLE BT

B. EVASION AIDS

1. MOBILE DECOY

a. TORPEDO DECOY

b. BREAK-TRACK DEVICE

III. INTEGRATED COMMAND DISPLAYS

IV. ANTI-SURFACE WEAPON

Figure 10

SSB(N). Figure 13 gives the geometry which was utilized in this study. To cover it very quickly: If the SSB(N) has a certain detectability range, the SSB(N) can detect the SSK which is searching for it to some range. If the SSB(N) attempts to evade, the intersection of the SSK detectability radii and the trapping area which is produced gives a resultant sweep

INTEGRATED SSBN DEFENSE SYSTEM

Research and Development Recommendations

- I. Systems Analysis
- II. Sonar - Phase II
- III. Classification
- IV. Countermeasures
  - A. Avoidance Aids
    - \*1. PEPS
  - B. Oceanography
    - 1. Phase I
      - a. Operations Analysis to Determine Role of Oceanography in SSBN Defense.
      - b. Reconnaissance Bottom Characteristics Measurements.
      - c. Reduction and Analysis of Convergence Zone Data.
    - \*2. Phase II
      - a. Detailed Bottom Characteristics Measurements
      - b. Comprehensive Study of Time Varying Upper 2000 feet.

\*Initiation dependent on Phase I recommendations.

Figure 11

### CATEGORIES OF THE THREAT TO THE POLARIS SYSTEM

- SURVEILLANCE or continuous cold-war tracking and trailing
- CLANDESTINE ATTRITION
- OVERT ATTRITION in a hot-war climate
- BLUNTING, or the blunting attempt of all-out war

Figure 12

width for the searching SSK, and most of the results we will talk about are in terms of this sweep width.

"The basic study was done as a type of game analysis. Figure 14 is a sample of one of the matrices which resulted from this study. If we plot the SSB(N) escape speed and the mean search speed of the SSK

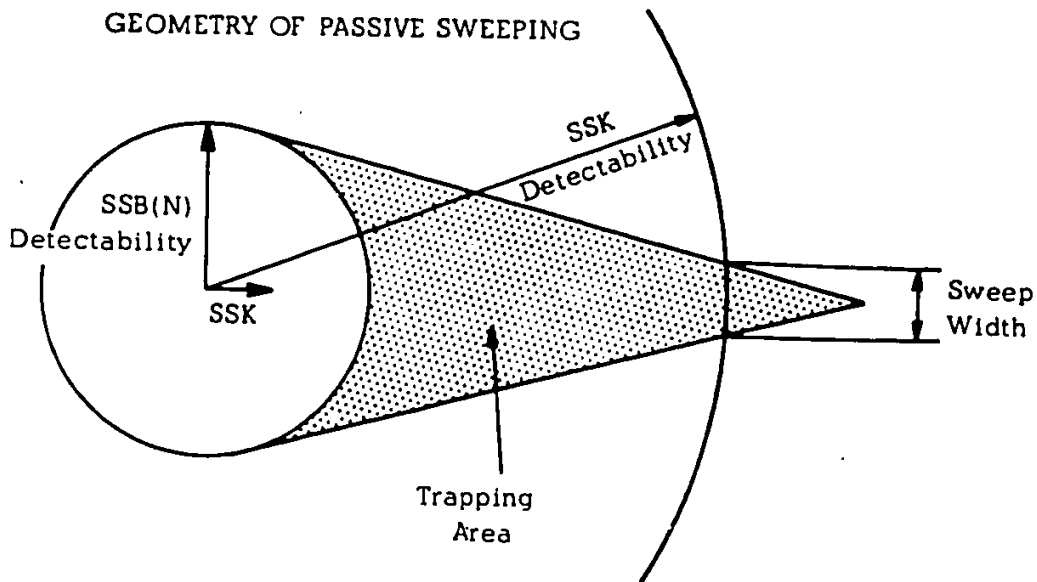

Figure 13

SYSTEMS APPRAISAL COMMITTEE DISCUSSION

GAME MATRIX (Example)

Escape Speed  $v$ , knots

		4	6	8	10	12	14	16	18	20
Mean Search Speed $u$ , knots	4	28	28	29	29	31	32	33	35	36
	6	42	42	42	43	43	46	48	50	54
	8	56	55	56	57	60	63	67	70	73
	10	70	68	69	70	74	79	85	89	93
	12	80	75	76	77	84	92	103	113	122
	14	85	78*	78*	78*	88	100	119	138	157
	16	83	73	72	71	83	98	127	160	195

\* Saddle Point

BQR-7 Sonars  
 SS2 Limited  
 400-Ft Layer  
 SSN 593 vs SSB(N) 608

Figure 14

for a variety of sonars, a variety of sea states, and many other varied conditions, we obtain a matrix of this sort. One usually found a saddle point in this matrix which indicated an optimal tactic for both the hunter and for the evader.

"The results of this study are summarized in figure 15. Here, we have plotted the resulting sweep rate as a function of the hider figure of merit, and the figures of merit are given for a variety of sonars -- the target submarine having the noise characteristics either of the SSB(N) 608 or the SSN 585. Early in our study, we decided that the standard snorkler so often used as a target was a very easy searcher for the SSB(N) to evade while on patrol. Our analyses therefore were centered mainly about a submarine having the noise characteristics of the SSN 585.

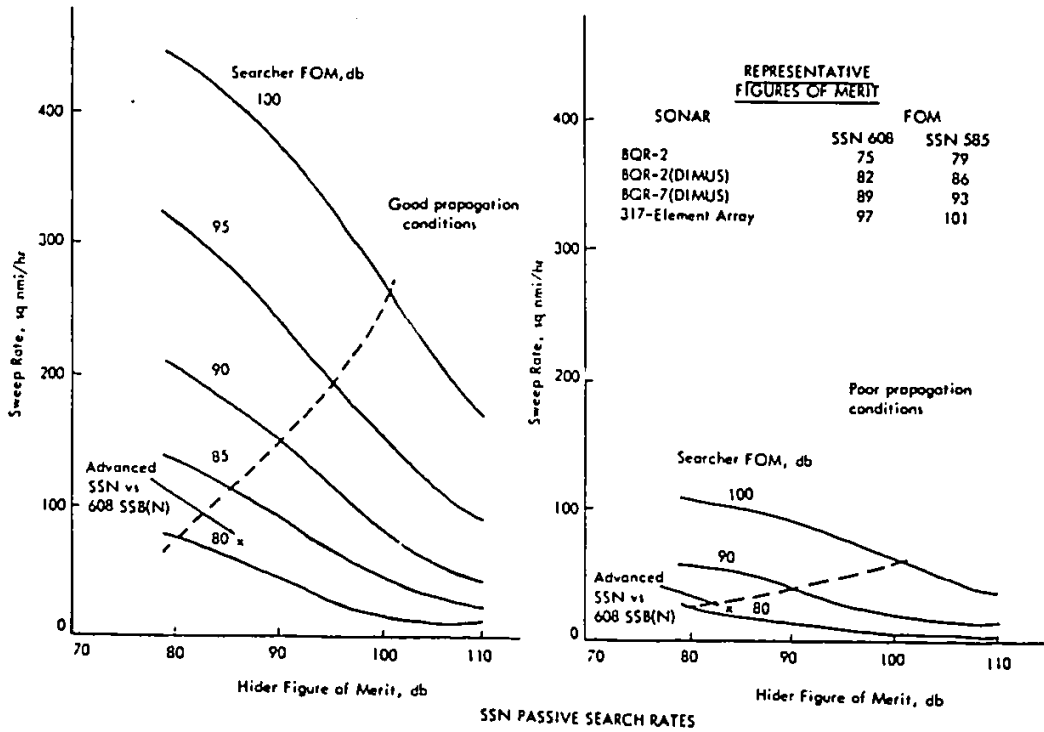

Figure 15

"The curves entered here as parameters are the figures of merit of the searcher; we have pictured conditions corresponding to a 400 foot layer and conditions corresponding to a 100 foot layer. The sweep rates that an enemy SSN of the current Soviet capability, which, incidently, corresponds to the noise characteristics of the USS NAUTILUS, would be about 10 to 20 square nautical miles per hour.

"A relatively advanced Russian submarine with a BQR-2, with the addition of pre-formed beam DIMUS processing, and noise characteristics of the 598-against our 608-Class in good condition would be located as shown on these curves, with sweep rates of about 80 square nautical miles per hour.



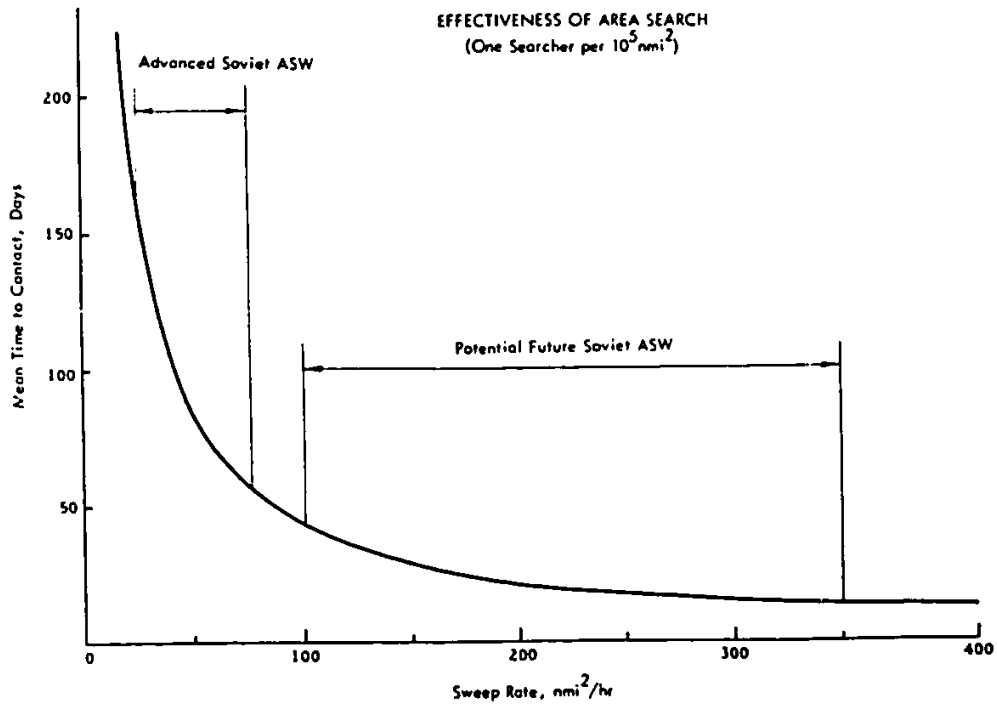
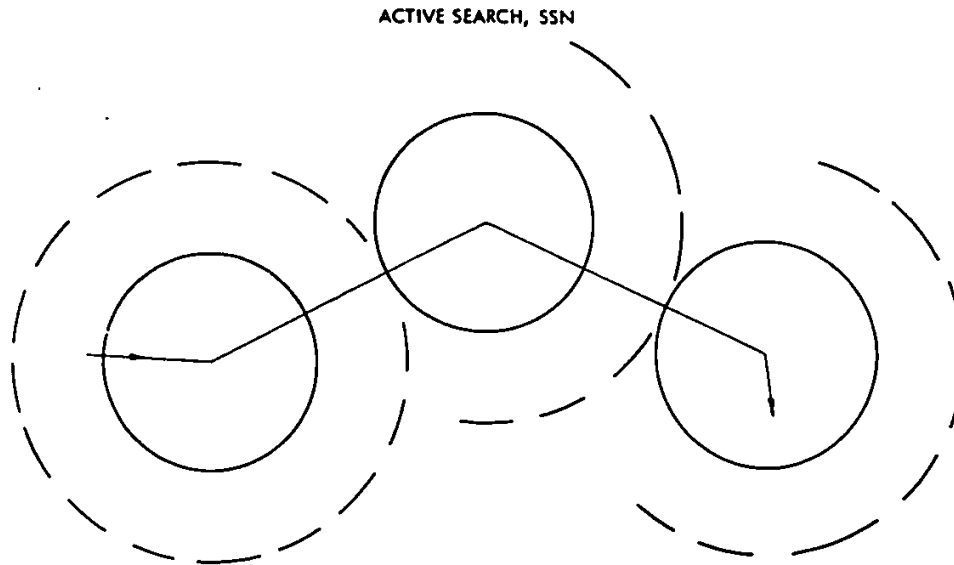

Figure 16

"If the enemy improved his sonar to this type of array, which I will define and discuss later, then sweep rates on the order of 350 to 400 square miles per hour might be achieved against our present SSB(N). However, a word of caution -- his classification problem will become extremely difficult for sweep rates of this magnitude.

"Figure 16 translates these sweep rates into something a bit more meaningful. If we look at mean-time-to-contact as a function of sweep rate, you can see where we will be in the immediate future. We postulated that this advanced Soviet ASW capability might be with us in 1968, with the mean-time-to-contact ranging from 60 to 150 days. The potential future Soviet ASW capability with sweep rates approaching the 350-400 level would range from perhaps 15 to 30 days. The figure presumes a density of one searcher, and one SSB(N), per 100,000 square mile area.



	SSN Sweep Rates	
	Active	Passive
Poor Sonar Conditions	36	28
Good Sonar Conditions	120	75

Figure 17

"We also examined the picture with active search, as shown on figure 17. We postulated that if the SSB(N) had an intercept receiver which gave a minimum of a 2:1 intercept ratio, then it would not be profitable for the SSN to search actively in a continuous fashion. However, a technique which does look somewhat promising is to run quiet to one spot, search out the area, turn off the active sonar, run quiet to another spot, and then illuminate the area again. Sweep rates which might be achieved with this tactic are given with the passive sweep rates for comparison.



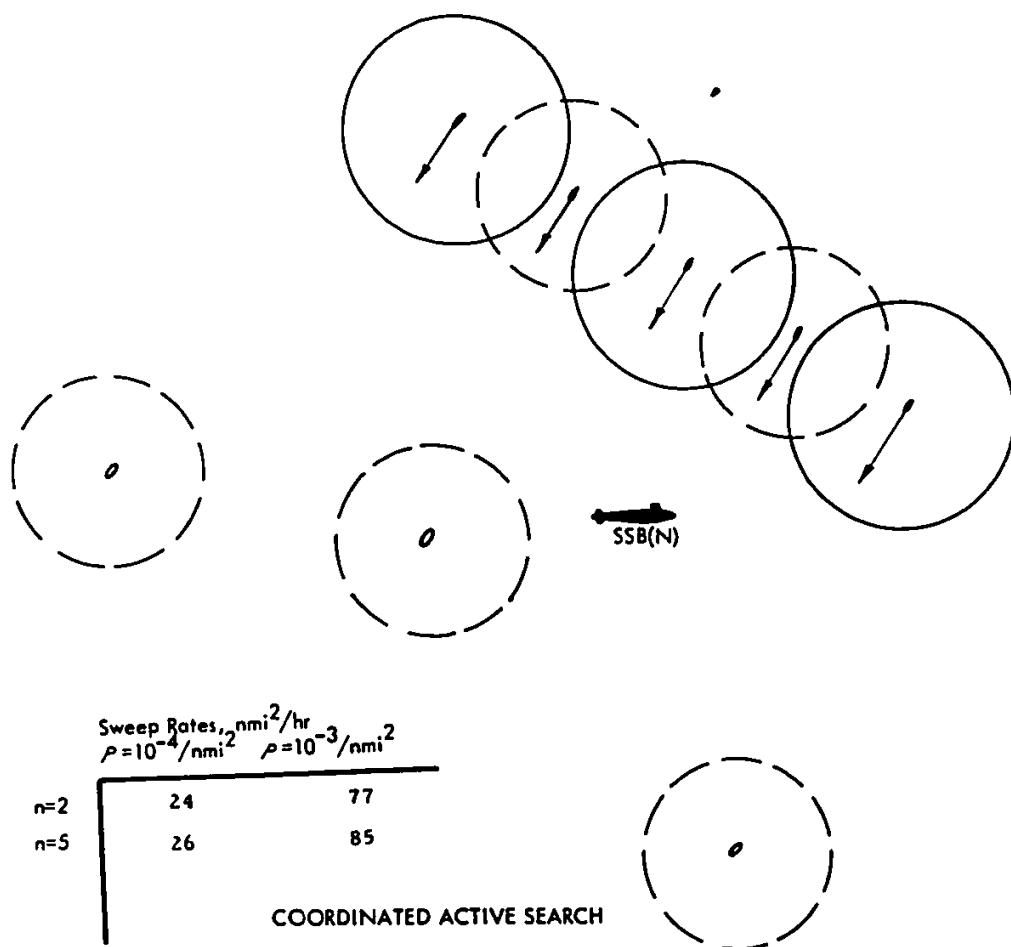

Figure 18

"Another tactic which we looked at was that of a coordinated surface/sub-surface search, as in figure 18. Here, a group of coordinated destroyers might be searching for an SSB(N) in conjunction with several passive SSK's. Sweep rates for various densities of surface searchers and various numbers of submarines are indicated here. This study would tend to indicate that sweep rates which might be achieved per surface unit are comparable to the sweep rates which might be achieved by an SSN.

"We looked at aircraft search, and found that the sonobuoy type search does not postulate a very significant threat. (See figure 19.) But, then we looked at what the Soviet might accomplish if wake detection were feasible. While we did not examine the feasibility of this concept, we did examine various widths and lengths of wakes which might be left by the submarine. Granting the presence of a rather large number of false

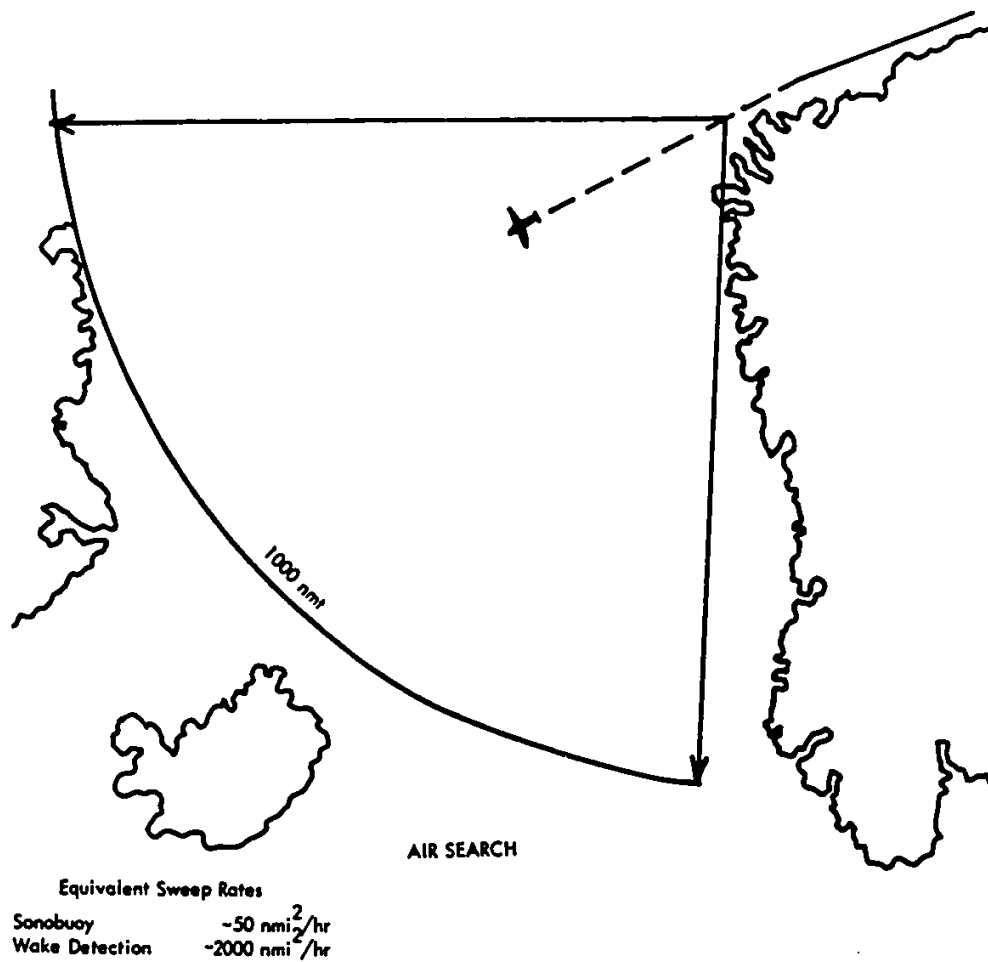

Figure 19

wakes which the aircraft would have to investigate, he still might be able to achieve sweep rates on an order which would constitute a serious threat if wake detection proves to be feasible.

"Next, the actual equipment recommendations. In the sonar area, figure 20, which we feel is really the heart of the defense system, we have recommended the development of a volumetric array that would utilize in the optimal fashion the entire bow volume of the SSB(N). Individual hydrophones would be scattered both before and below the torpedo tubes in this configuration, and DIMUS processing techniques would be utilized.

"In addition to this, we recommend the development of a towed array based on the modular concept which has been developed for sur-

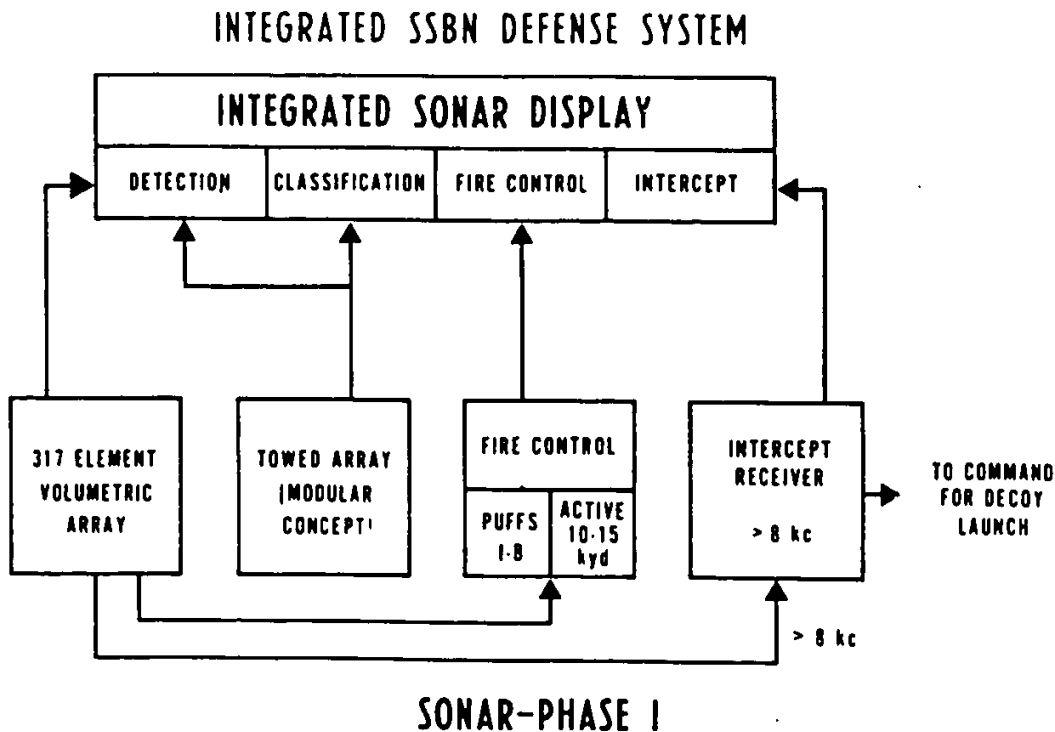

Figure 20

face ship application. This concept utilizes a single conductor towed cable. We are recommending a 300-foot long array which would be primarily for classification, although it could also give an additional hindsight detection capability which the bow mounted array did not have.

"In the fire control area, we are recommending a version of the PUFFS system which we will discuss later, and a medium range active sonar. You will notice now that the emphasis is away from a long range active sonar for the SSB(N) and towards the maximization of the passive detection capability; we also recommend an intercept receiver which is based on DIMUS processing techniques with a separate sail mounted array for intercept of signals above 8 kc. This receiver would give indication of an approaching torpedo and utilization of these two arrays for signals below 8 kc.

"To support the recommendations for the volumetric array, figure 21 is a comparison of sonar systems which might be considered for the

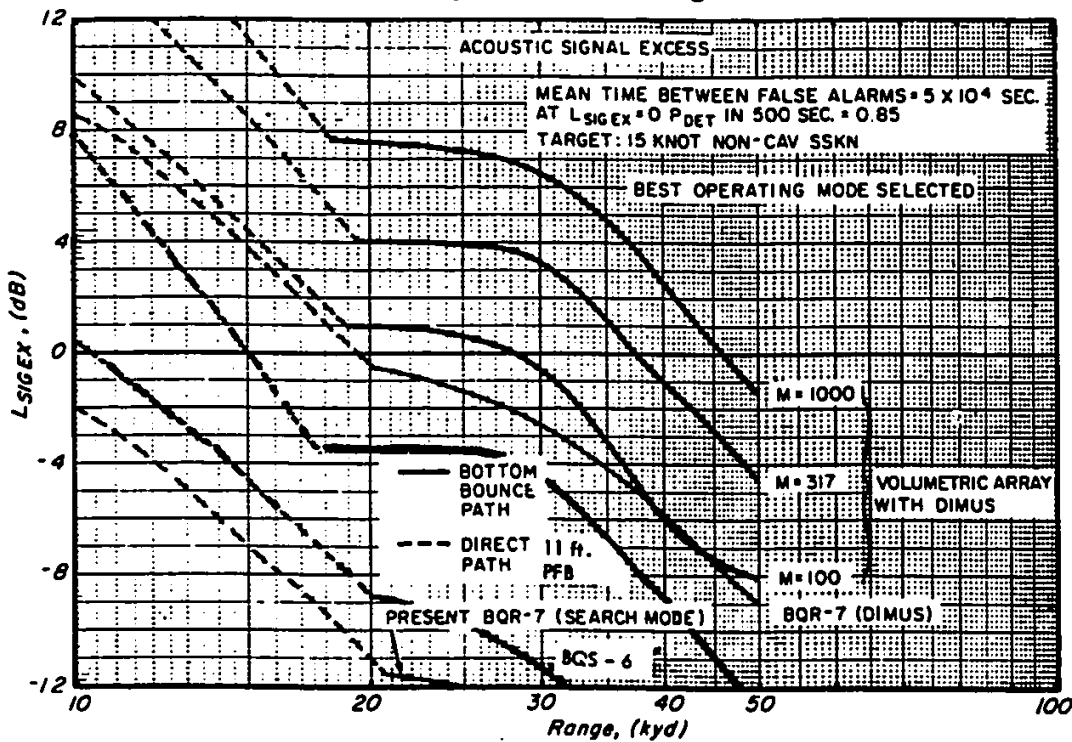

Figure 21

SYSTEMS APPRAISAL COMMITTEE DISCUSSION

SSB(N), where we have plotted this range as a function of signal excess. Now, in this comparison we have deviated slightly from our standard target. Here the target is about 5 db quieter than the SSN 585 target which we assumed in most of the analyses. The dotted lines indicate the direct path propagation characteristics. The solid lines indicate the performance in the bottom bounce mode.

"At present, our BQR-7 shows up as a very poor performing sonar. With the addition of DIMUS processing to the BQR-7, we might bring the level of performance up as shown. However, with a volumetric array having either 100, 317, or 1,000 elements we can see the sort of performance that we might expect. For reference, we have also plotted the present BQS-6 performance. That is calculated. It is not the actual performance which one might expect from a modified version of the BQS-6 using an 11-foot sphere. The present BQS-6 has a 15-foot sphere with free formed beams. (See figure 22)

"If we look at this comparison in another way, and ask ourselves what is the relative cost of achieving a certain probability of bottom bounce detection at 30 kiloyards -- taking our 317-element volumetric array (the one we recommend for development in the PTA) which has a probability of bottom bounce detection at this range of about .65 as having a unit cost of one -- we see that our BQR-7 with pre-formed beams has about four-tenths the cost of the 317-element array.

"The 1,000-element array and full surface conformal array are, with today's processing techniques, highly expensive. However, if optical beam forming techniques are developed, possibly with micro-circuitry techniques applied to sonar processing, the cost differential might disappear and the price would compare favorably with this array. However, we are still not picking up too much in probability of detection. The present BQS-6 and the 11-foot truncated sphere are shown for reference.

"Figure 23, which shows the possible PUFFS variations, indicates that the present installation which is going on the BARB is inadequate

RELATIVE COST AND PERFORMANCE OF PROPOSED SONAR ARRAYS

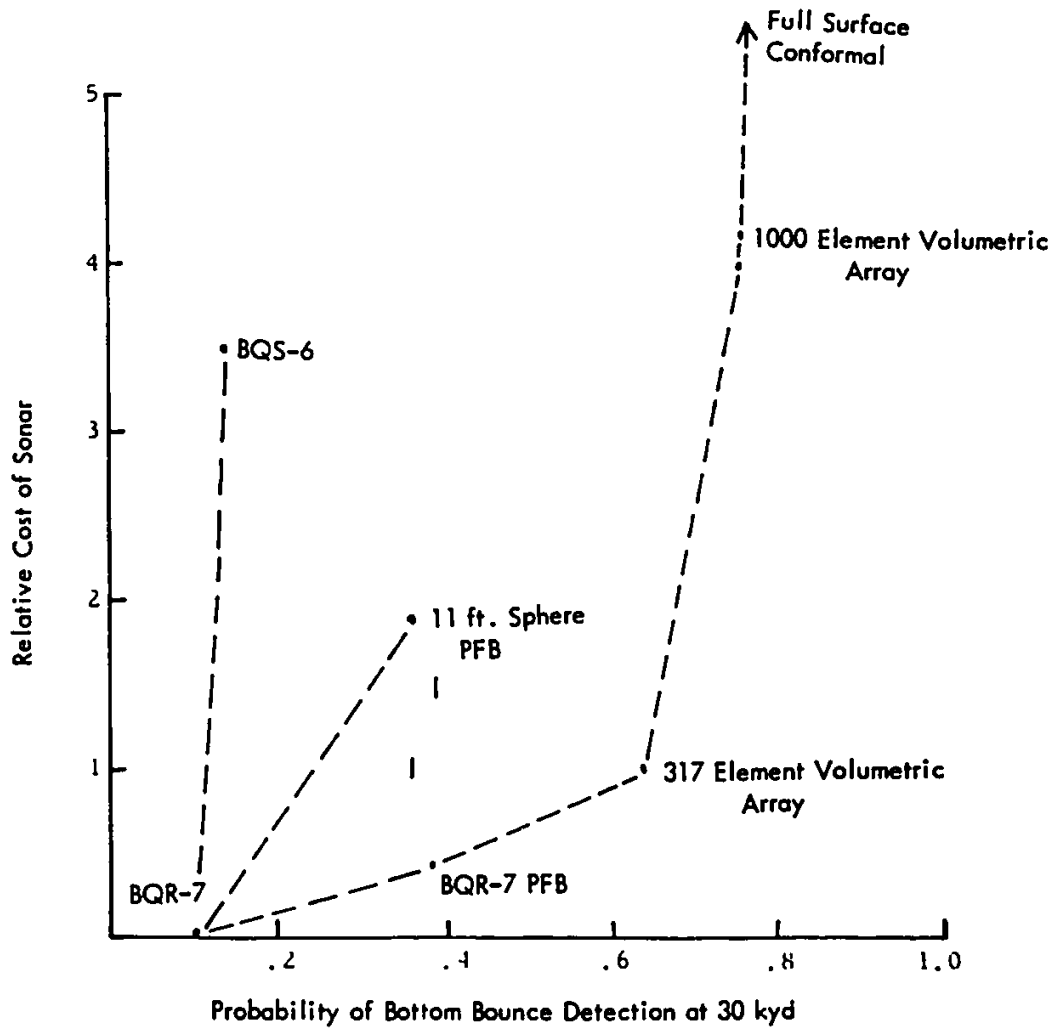

Figure 22



Alternate PUFFS Configuration

TABLE V

<u>Configuration</u>	<u>Prototype Development time</u>	<u>Comments</u>
I. AN/BQG-2A [Modified for SSB(N)]	18 mo.	Inadequate Performance for SSB(N).
IA. I plus Auto-Tracker	36 mo.	Acceptable Range. Electronics Performance Marginal.
IB. IA plus Digital R-O Computer	36 mo.	Recommended for SSB(N).
IC. Redesigned AN/BQG-2A	54 mo.	Rapid Scan, Auto-Track Redesigned electronics. Multi-target Track Bearing accuracy improved to $\pm .03^\circ$ . Support not recommended for SSB(N).
II. Advanced PUFFS	78 mo.	Microcircuit Techniques: Transient noise ranging, non-straight line arrays. Support recommended in principle only. Alternate methods of passive ranging must be considered.

Figure 23

for the SSB(N). The detection range against a quiet target is limited to about 6.4 kiloyards. We felt that we need range information out to about 10 kiloyards minimum.

"One might add an auto-tracker to this basic PUFFS, and replace the present analog R-Theta computer with a digital computer; this is

actually the version that we have recommended. While this does not permit one to make initial detections at a ten-kiloyard range, it will permit an operator, once he is pointed by the bow array in the proper direction, to get range estimates at about 10 kiloyards.

"A new design of the PUFFS system is not recommended for the SSB(N) for various reasons. Concerning the various advanced PUFFS concepts, we feel that any additional work in PUFFS should not be done in an independent fashion, but coordinated with other development efforts such as are made possible by the installation of the volumetric array. In the area of intercept receiver design, figure 24, the SSB(N) at present has the DUUG-1 which is totally inadequate due to the very high false alarm rate. There is a modification of the DUUG-1 developed by USNUSL but, in spite of the claims, this model does not promise much improved performance over the present.

"The AN/WLR-5, a prototype system, has been developed and an evaluation of this system is limping along but may be done any day. There is an advanced research program being conducted at the General Electric Company utilizing some of the circuit techniques which were developed for the WLR-2. We have proposed a different type of approach which would attempt to minimize false alarms by separate but simultaneous threshold criteria on the three characteristics of the intercepted signal. We feel that the importance of the development of an adequate intercept receiver certainly warrants support of both of these programs.

"In view of the late hour, we had better hasten on to countermeasures, figure 25. Our recommendations here are for an expendable BT and for a mobile decoy device which would be stored externally to the submarine.

"In order to permit that the submarine may obtain a temperature profile, and find out a little more about his patrolling environment without the necessity of leaving patrol depth, we have recommended the development of an expendable BT, figure 26, which would be ejected from the signal tube of the submarine. The BT would have a balloon attached to it that would enable it to rise to a depth of about 25-30 feet, when

INTEGRATED SSB(N) DEFENSE SYSTEM  
Intercept Receiver Concepts

1. DUUG-1 Presently installed on SSB(N). Inferior electronics. High false alarm rate. Manned. No frequency indicator.
2. DUUG-1 Mod Modification undertaken by USN/USL. Adds frequency indicator. Removes grounds.
3. AN/WLR-5 Matrix display. Under evaluation since August 1963. Preliminary indication of high false alarm rate. Should have bearing-frequency analyzer and signal level indicator. Unit cost - \$170K.
4. Advanced Research Based on IF correlator developed for AN/WLR-2 Study program. Proposal for development due 1 July.
5. Proposed PFB Concept Digital processing with pre-formed Beams. Uses bow array below 8 kc, small sail array Above 8 kc. Minimize false alarms by separate but simultaneous threshold criteria on signal bearing, frequency, and amplitude.

Figure 24

the balloon would collapse. The expendable BT would descend, telemetering back temperature at depth to the submarine.

"These expendable BT units for surface ship application have been developed and cost about \$10.00 each; the development of that bag should not increase the cost of these units beyond the point where we could consider them as expendable items.

INTEGRATED SSB(N) DEFENSE SYSTEM  
COUNTERMEASURES

- A. AVOIDANCE AIDS
  - 1. EXPENDABLE BT
- B. EVASION AIDS
  - 1. MOBILE DECOY
    - a. TORPEDO
    - b. BREAK-TRACK

Figure 25

"Figure 27 is a broad consideration of countermeasures and an extremely complicated area it is. This figure includes the sort of analysis we attempted in order to get some handle on what really constitutes an effective countermeasure device. We have tried to categorize all possible types of countermeasures for torpedoes which we might visualize. In going through this entire evaluation, the one thing that appears to hold the most promise is the development of a mobile decoy with speed to match that of a torpedo which can actually act to lure the torpedo beyond acquisition range.

"We also examined various concepts for breaking continued track, as summarized in figure 28. We went through the process of listing all conceivable tactics for breaking track. One of the analyses in the PTA is extensively concerned with the effectiveness of own-ship maneuvers; it concludes that this by itself is a rather ineffective tactic.

"Now most attempts to develop track devices have failed in the past because people have tried to develop a submarine simulator, and you just cannot simulate all the characteristics of a submarine unless you have another submarine itself. People have talked about developing a countermeasure which would also be launched from a torpedo tube, but this is also entirely unsatisfactory. The approach we would prefer is to utilize the same mobile decoy that we used as a torpedo decoy and

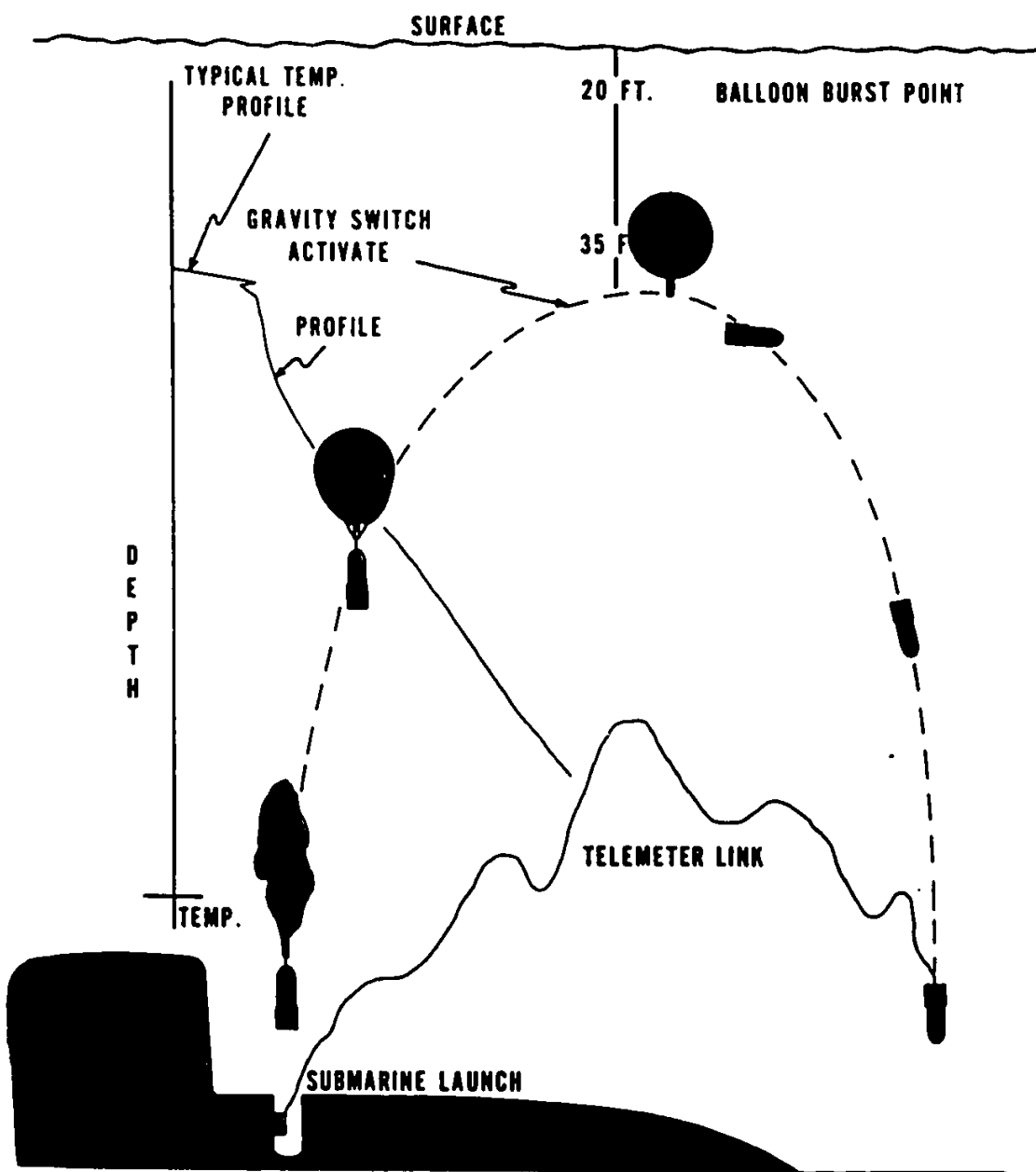

**PROPOSED BATHYTHERMOGRAPH DEVICE**

Figure 26

TORPEDO COUNTERMEASURE CONCEPTS

COUNTERMEASURE CATEGORY		EASE OF IMPLEMENTATION	EFFECTIVENESS				OTHER FACTORS	PROMISE OF ADEQUATE PERFORMANCE
			REQD ALERTING RANGE	FLEXIBILITY	FIRST ATTACK	RE-ATTACK		
OWN SHIP MANEUVERS	SPEED	NO	LONG		DEPENDS ON ALERT		AID TO	VERY QUESTIONABLE
	TURN	HARDWARE REQUIRED	MODERATE			NO PROTECTION	OTHER CONCEPTS	LITTLE
	DEPTH CHANGES		MODERATE		QUESTIONABLE	QUESTIONABLE		QUESTIONABLE
JAMMING (DENIAL OR INTERFERENCE)	HULL MOUNTED (RANGE DENIAL)	RELATIVELY EASY	SHORT	EFFECTIVE ONLY VS TORPEDOS			AID	LITTLE
	EJECTED (RANGE DENIAL)	RELATIVELY EASY	MODERATE	USING RANGE FOR ATTACK			SEARCHER	LITTLE
	(RANGE, BEARING, ELEVATION DENIAL)	VERY DIFFICULT	MODERATE		GOOD	GOOD	CLASSIFICATION	LITTLE
TORPEDO	DESTRUCTION	VERY DIFFICULT	LONG		EXCELLENT		BEST FUZING (GUIDANCE PROBLEMS)	LITTLE
DECOYS (SUBSTITUTION OF FALSE INFORMATION)	HULL MOUNTED (DAMPING)	RELATIVELY EASY	SHORT	VERY DIFFICULT	GOOD	GOOD	REQUIRES DETAILS OF ATTACKER	LITTLE
	TYPIC EJECTED	RELATIVELY	MODERATE		GOOD	QUESTIONABLE	REQUIRES LARGE NUMBERS	QUESTIONABLE
	HORIZONTAL					QUESTIONABLE		QUESTIONABLE
	TOWED	DIFFICULT	SHORT		GOOD	QUESTIONABLE		QUESTIONABLE
	MOBILE	DIFFICULT	MODERATE		GOOD	GOOD		GOOD



 CONCEPT WEAKNESS,  
 MAJOR CONCEPT WEAKNESS.

Figure 27

mount a simulator on the hull of the submarine which for the period of time that you engaged in a break-track maneuver would make the submarine itself look like a deployed decoy.

"This appears to be a quite feasible tactic. The only thing that requires considerably more examination is how the effectiveness of this tactic can be enhanced by maneuver and other types of confusion aids which are listed here.

"Figure 29 is an artist's sketch of how we propose to house these decoys. Note the scale of size that we are shooting for. These decoys would be housed on two drums, about two feet in diameter, installed in

11/11

SYSTEMS APPRAISAL COMMITTEE DISCUSSION

BREAK TRACK COUNTERMEASURE CONCEPTS

COUNTERMEASURE CATEGORY		EASE OF IMPLEMENTATION	EFFECTIVENESS		COMMENTS ON PROMISE OF ADEQUATE PERFORMANCE
			STRENGTHS	WEAKNESS	
OWN-SHIP MANEUVERS		NO HARDWARE	MANEUVERS CAN BE REPEATED INDEFINITELY, A LOW PROBABILITY OF SUCCESS PER MANEUVER CAN BE TRANSLATED TO A HIGH PROBABILITY OVER A PERIOD OF TIME.	REQUIRES SIGNIFICANT, SHORT TIME PERIOD VARIATIONS IN THE FALTSOS DETERMINING SONAR DETECTION.	EFFECTIVENESS UNKNOWN
WEAPONS	HOMING MINE	DIFFICULT	DETERS TRACKER FROM HIGH SPEED BLIND BASHES, REQUIRES TRACKER TO MOVE ON OFFSET COURSE IN PURSUIT.	REQUIRES AGGRESSIVE ACT	WOULD AID EFFECTIVENESS OF MANEUVERS SIGNIFICANTLY.
	CONVENTIONAL TORPEDO	IN EXISTENCE	ELIMINATED TRACKER	REQUIRES VERY AGGRESSIVE ACT	AS EFFECTIVE AS THE WEAPON PERFORMANCE
JAMMING	MOBILE NOISE OR VERT	MODERATE	DISTRACTS OR BLINDS TRACKER FOR PERIODS OF TIME.	TRACKER CAN MANEUVER TO PUT JAMMING IN INEFFECTIVE POSITION	WOULD AID MANEUVERS, DISTRACTION MAY NOT LAST FOR SUFFICIENTLY LONG TIME PERIODS.
	STATIONARY	EASY			
DECOYS	SSBN NOISE SIMULATOR	VERY DIFFICULT	PASSIVE SONAR CANNOT DISTINGUISH SIMULATOR FROM TARGET.	ACTIVE SONAR CAN DISTINGUISH SIMULATOR FROM TARGET.	IT APPEARS THAT THESE DEVICES MUST BE COMBINED INTO
	ECHO REPEATER	DIFFICULT	ACTIVE SONAR CANNOT DISTINGUISH SIMULATOR FROM TARGET.	PASSIVE SONAR CAN DISTINGUISH SIMULATOR FROM TARGET.	ONE VEHICLE, OR MUST BE USED WITH EXTENSIVE NOISE AND JAMMING.
	FULL MOUNTED DECOY SIMULATOR	MODERATE	EASIER METHOD FOR ACHIEVING SIMILARITY BETWEEN TARGET AND DECOY.	CAREFUL ANALYSIS BY TRACKER MAY PERMIT DISTINGUISHING	MAY BE EFFECTIVE IF USED WITH MOBILE JAMMING AND MANEUVERS AND APPROPRIATE MANEUVERS.

CONCEPT WEAKNESS 
  MAJOR CONCEPT WEAKNESS

Figure 28

the sail. These drums would rotate similarly to a revolver magazine, and at the proper time the flap would come down; the decoy would be deployed into the slipstream, and take off. We should be able to launch within considerably less than one minute from the receipt of the warning of torpedo approach.

"In the area of defensive weapons, we have done a rather extensive analysis. Figure 30 indicates that there are two alternate approaches which one could make. One system gives the SSB(N) three weapons -- one specifically designed for the SSB(N) defense, one weapon for anti-submarine purposes, and one weapon for anti-surface shipping.

# DOUBLE DRUM DECOY LAUNCHER

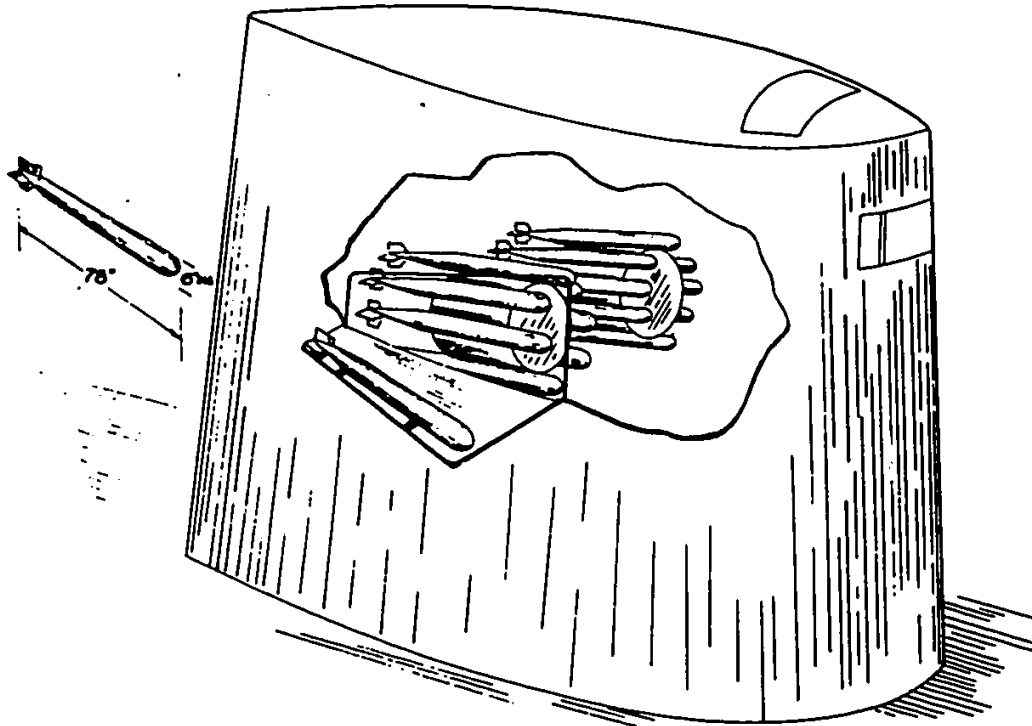
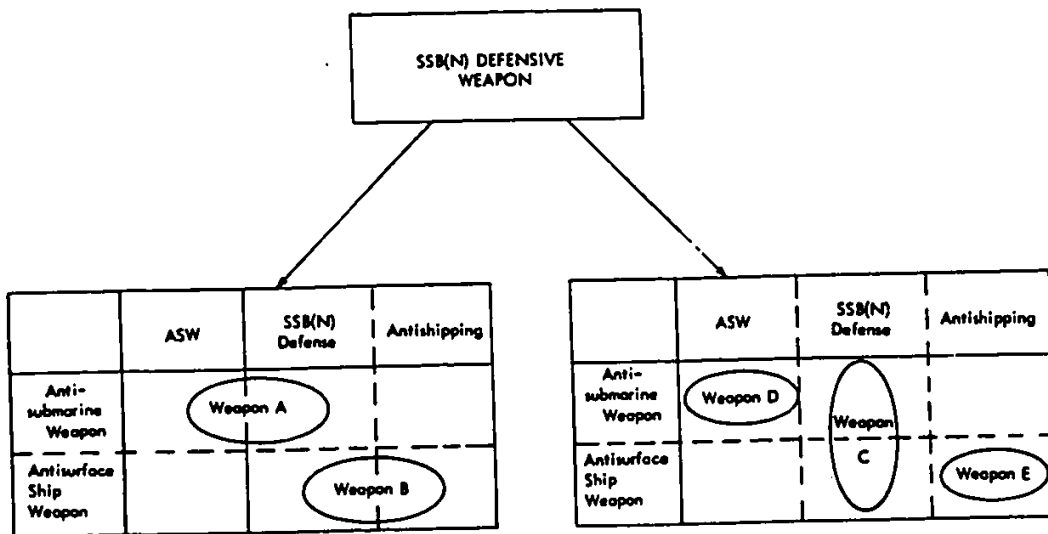

Figure 29



ALTERNATIVE APPROACHES TO SSB(N) DEFENSIVE WEAPONS

Figure 30



## SYSTEMS APPRAISAL COMMITTEE DISCUSSION

"It seems much more reasonable to approach the SSB(N) defensive weapon picture by accepting the EX-10 program which is now under development. We feel that if it were aggressively pursued that the development could be hastened by a year or so, and recommend the immediate development of an anti-surface ship weapon, a torpedo which would be ready by 1968 with some slight compromises in the countermeasure proof characteristics and some compromises in the wake-less propulsion area."

Mr. Parran recalled that the EX-10 had been considered and rejected by a Systems Appraisal study about two years back, but Dr. Craven explained that in the two years time, great advances had been made in our knowledge of the spread of interactions between the two submarines involved. "We have grown in our sophistication about the interactions," continued Dr. Craven, "at least an order of magnitude since the earlier study. As I recall, the major objection to the EX-10 was the simple fact that its use called attention to the existence of the SSB(N); I think the general policy is still to avoid the use of weapons."

"Hopefully, an emphasized sonar development may allow us to keep that policy in the future," replied Mr. Miller. "Our study suggests a weapon with less sophisticated characteristics than were planned for the EX-10. The Study Group has recommended that SUBROC not be included in the SSB(N). In figure 31 we have the probability that the SSB(N) is destroyed if it detects the SSK. The SSK is equipped with a SUBROC weapon as also is the SSB(N), and the reliability of these weapons is taken at .7. If the enemy SSK has sonar performance corresponding to BQR-2 DIMUS, which is roughly the same as the BQR-7 DIMUS or the volumetric array, and we took a look at the probability that the SSB(N) is destroyed, then we get the indicated curves.

"If the SSB(N) is purely aggressive and goes out to kill, once he detects the SSK, the top line is the probability he has of being destroyed in an exchange of weapons. If the SSB(N) adopts a purely evasive strategy when he detects the SSK, and attempts to evade, the resultant probability that he will be destroyed is seen on the third line from the top.

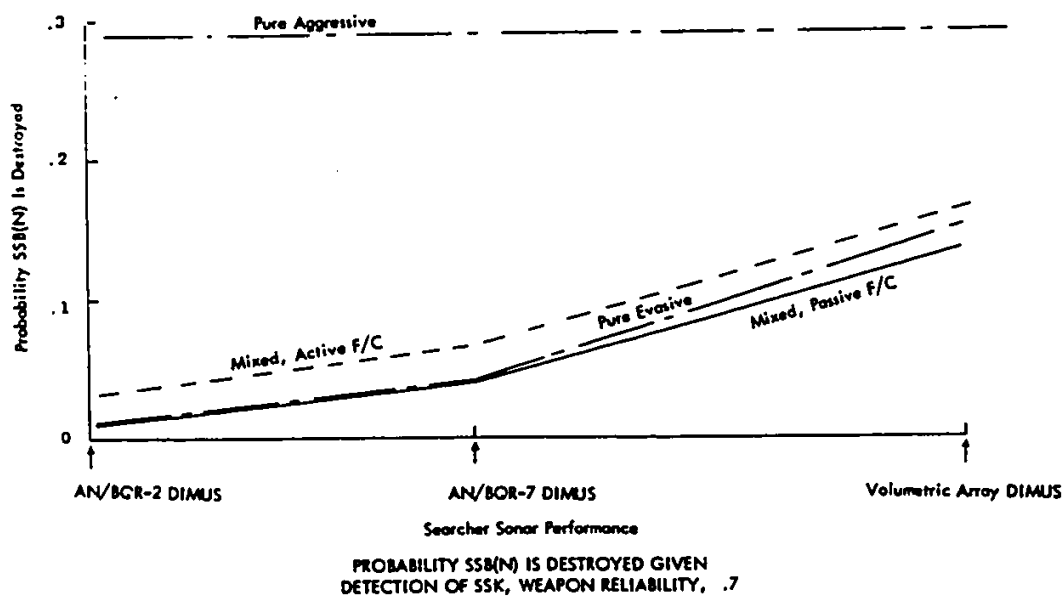

Figure 31

the SSB(N) can adopt a mixed strategy; he can utilize a long range active fire control system to pin down the enemy and then fire SUBROC, or he can obtain a crude range, accurate to about 25 percent, and fire a salvo of two SUBROC's. If he elects this weapon exchange, the remaining curves indicate the probability that he will be destroyed.

"The summation of this analysis, and this is just one of the studies developed to support our conclusion, is that the SSB(N) is far better off remaining in a purely evasive position, not employing a long-range weapon as SUBROC, but depending upon torpedoes to ranges of about 10 to 15 kiloyards.

"You might also note that the enemy's performance against the SSB(N) improves as he improves his sonar abilities, even assuming

that the SSB(N) has the volumetric array. We also assumed that the performance of the passive sonar of the SSB(N) would be penalized about 5 decibels if the ship installation included a large active sonar.

"Figure 32 defines our Phase II thought on sonar. We definitely recommend that a basic research program be instituted on advanced array design displays and signal processing techniques. This is one example of the things which might be done in this research program.

## INTEGRATED SSB(N) DEFENSE SYSTEM

### Sonar - Phase II

Basic research on arrays, displays, and signal processing.

Examples of techniques and concepts to be considered:

- a. Optical Beamforming.
- b. Microcircuitry Techniques.
- c. Passive Ranging Integration (PUFFS on towed array).
- d. Alignment and Beam Stabilization.
- e. Advanced Display Concepts.
- f. Detection of Ultra-quiet Targets in the Presence of High Level Long Range Targets.
- g. Transient Signal Detection.
- h. Controlled Position Towed Array.
- i. Independent Satellite Sensor Vehicle.

Figure 32

Another approach which looks quite promising for the future, is the use of a towed array as part of the PUFFS baseline in ranging integration.

"In the area of classification, figure 33, we found very little of promise today. Most of our classification effort is based on Lofargram comparison techniques, and consists of attempts to develop better computer programs to assist an operator who is already fairly well trained. We feel it is necessary to do some very basic analysis as to what is really the basic process of recognition and how we recognize information. The second phase of this program would be a concerted attempt to determine what characteristics in the information received by the sender might be available to utilize with the work done in developing equipment. This is a program which we feel should run for six years, with the first two phases taking about four years. It should be funded at a rather husky level.

"Microcircuitry is important because of the volume problem on the SSB(N), and if one goes to larger arrays it is almost essential to go to the microcircuitry techniques. We do not think this is necessary

### INTEGRATED SSB(N) DEFENSE SYSTEM

#### Classification

- Phase I     Conduct basic research studies on recognition mechanisms.
- Phase II    Conduct basic research studies to determine characteristics of sonar information which can be used for classification.
- Phase III   Develop equipment specifications, design and build classification equipment based on studies in Phases I and II.

Figure 33

SYSTEMS APPRAISAL COMMITTEE DISCUSSION

for the 317 element array, but for advances beyond this I think it might pay off.

"In the area of oceanography, figure 34, we have heard oftentimes the comment that perhaps the SSB(N) should carry an oceanographer on board. If one asks himself how the oceanographer can help the SSB(N) in this evasive mode of patrol, one is rapidly stopped dead in his tracks. We feel that it is essential to do a thorough analysis to determine exactly what oceanography has to contribute to the enhancement of the SSB(N) defense potential. In addition, we feel it is necessary to do some primary reconnaissance survey work in the SSB(N) patrol areas to determine the potential of bottom bounce techniques in these areas. We also feel that some of the data on convergent zone detection which is now in the ocean-

INTEGRATED SSB(N) DEFENSE SYSTEM  
PROPOSED OCEANOGRAPHY PROGRAM

- |          |  |
|----------|--|
| Phase I  | 1. Operational Analysis to Determine Role of Oceanography in SSB(N) Defense. |
|          | 2. Reconnaissance Bottom Characteristics Measurements.                       |
|          | 3. Reduction and Analysis of Convergence Zone Data.                          |
| Phase II | 1. POLARIS Environmental Prediction System.                                  |
|          | 2. Detailed Bottom Characteristics Measurements.                             |
|          | 3. Comprehensive Study of Time Varying Upper 2000 Feet.                      |

Initiation of Phase II Dependent on Phase I Recommendations.

Figure 34

ographic data center should be developed and fed into the analysis to determine the effectiveness of an enemy searcher making use of convergent zone information within the SSB(N) patrol area.

"Depending upon the results of the Phase I program, we might recommend as a Phase II program the extension of ASWEPS prediction information into the SSB(N) patrol area. Another recommendation which might grow from the Phase I program would be a detailed bottom characteristic measurement program within the SSB(N) patrol area. Then, if this analysis determines the exact impact on evasion and defense of the time variations of this upper 2000 feet, we would recommend that a comprehensive study of the time variations of the environment of the patrol areas be initiated.

"If silence is the best defense tactic for the SSB(N)," asked Mr. Applebaum, "Why do you give it an EX-10 torpedo?"

"We do not mean that the EX-10 is better than SUBROC," replied Mr. Cotton, "but rather that SUBROC by its nature cannot serve as a general purpose weapon because of the attending safety and political requirements."

"Does the addition of SUBROC give greater survivability to the SSB(N) than it had with only the EX-10?" inquired Mr. Applebaum.

"You must remember that there is more than SSB(N) survival being considered here," replied Dr. Craven. "A SUBROC detonation that would possibly destroy the SSB(N) can still invalidate the FBM weapon system, so we have two kinds of casualties possible. Further, this study has already indicated that having a SUBROC capability does not improve the survival chances for either the submarine or the system."

"Evasion is the best answer for the SSB(N)," added Mr. Cotton, "and the addition of the SUBROC does not improve survival chances in an evasive environment. There may be a set of circumstances in which the SUBROC would help survival, but we have not yet been able to identify them."

"He would use the EX-10," explained Dr. Craven, "when his evasions had failed him and it seemed certain that the enemy has closed in to a point where the SSB(N) has no other course open than to fight."

"If the enemy sonar improved materially," continued Mr. Cotton, "so that the SSB(N) commander would know that he was in serious trouble the instant that he realized he was detected by the SSK, then the picture would change. Under those conditions, the SSB(N) would possibly be better off striking first. As things are now, the differences in sonar give the SSB(N) an advantage that he would not wish to throw away by starting an attack. If he allows the other person to initiate the conflict, the SUBROC duel would not usually end in favor of the SSB(N)."

"A further problem here is the question of whether the SSB(N) can evade a modern sophisticated submarine with a close-on-board active sonar system once the initial contact has been made," resumed Mr. Miller. "If the SSK detects at less than 18 kiloyards, then our analysis suggests that it is rather difficult for the SSB(N) to evade or break track by simple maneuvering. His abilities to break track depend in a large way upon the variations in the wave propagation characteristics. This is an area in which we need a great deal of data to validate some of the analytical work we have done. Two years ago, there was a study that suggested that breaking track was relatively easy, but we have become better informed since then, and are equipping ourselves with far better sonars."

Mr. Applebaum suggested the possibility of extended cold-war tracking and trailing, but Dr. Craven replied that such tracking would have little value unless the enemy were to regularly announce to the SSB(N) that he was indeed being tracked and trailed; such an announcement would probably be done by periodic use of active sonar.

"We have some studies on this problem," said Mr. Cotton, "based upon models of the factors determining our present sonar abilities. First, we find that if the enemy SSK can close to within 1000-2000 yards, then the track cannot be broken. Next, we assume contact at an initial

range of 12 to 16 kiloyards is made by an SSK of SKIPJACK-Class performance equipped with a sonar similar to the BQR-2 with DIMUS, and that the SSB(N) is immediately aware of the contact and tries to break it by changing speed and depth and other evasions. In the usual models of this game, the time variations and propagation conditions are not included. In this analysis, we assumed that we do have time variations which are characterized by mean time in change of detection conditions of five minutes or twenty minutes. The game then proceeds in five minute steps.

"After the first step, a new set of sonar conditions would be chosen from the distribution, and these conditions would be studied. We found that when the initial separation is as small as 8 kiloyards between the SSK and SSB(N), (the SSK has the higher running speed) the probability of the SSB(N) successfully preventing the SSK from closing to one or two kiloyards is very low. This probably improves rather rapidly as the initial separation increases.

"If the SSK cannot make this blind run, then the situation is more favorable to the SSB(N) as the SSK has continually to worry about a weapon being launched. Nonetheless, if the initial separation occurs at rather short ranges, the probability is, literally, that the SSK can close on the SSB(N) but it really does not tell us anything about what happens in the next ten days after the SSK has closed to 2000 yards. The question has not been answered. This exercise, incidentally, did not include any active sonar.

"Figure 35 shows a recommendation we have forwarded to CNO via CNM. First, that the development which is indicated in the PTA can be done, be coordinated, and accomplished under the Project Manager and be funded under Navy Management funds, and that the necessary additional funding for this be provided as soon as possible. This will be forwarded to CNO within ten days; we need not speculate about the outcome, but hopefully the program will be funded and will proceed at a pace which would permit us to install the equipment which we have talked about in 1968 overhauls.



SYSTEMS APPRAISAL COMMITTEE DISCUSSION

INTEGRATED SSBN DEFENSE SYSTEM  
IMPLEMENTATION OF RECOMMENDATIONS OF PTA

1. THAT ALL RESEARCH AND DEVELOPMENT EFFORT IN DIRECT SUPPORT OF THE INTEGRATED SSBN DEFENSE SYSTEM BE COORDINATED UNDER ONE PROJECT MANAGER.
2. THAT THE SYSTEM BE FUNDED UNDER THE NAVY MANAGEMENT FUND.
3. THAT, SINCE THE PURPOSE OF THE SSBN INTEGRATED DEFENSE SYSTEM PROPOSED TECHNICAL APPROACH IS TO INSURE THE CONTINUATION OF THE CURRENT HIGH DEGREE OF SSBN SURVIVABILITY, ONE OF THE BASIC COMPONENTS OF THE DEPENDABILITY OF A NATIONAL STRATEGIC MISSILE SYSTEM, THE NECESSARY ADDITIONAL FUNDS BE PROVIDED AS SOON AS POSSIBLE.

Figure 35

"Our study will never be complete, and we do not regard the study as completed with the finishing of the PTA. The next step is the development of a PCP, a proposed program change proposal, then a TDP, a technical development plan, and the need for additional systems analysis to pin down other areas.

"You will note that we neglected the area of noise almost completely in our study. This is not an oversight on our part. We found extreme difficulties in ferreting out the information which we need to do the studies in depth which are contained in this PTA. So, the noise study was postponed. There are other areas, such as harbor defense, that we did not cover, and we need much more detailed information on system design of the components we have recommended here. Hopefully, we will be able to do this in the ensuing months."

On conclusion of this study of the SSB(N) defensive posture, Captain Sanger thanked Mr. Miller and observed that the lateness of the hour precluded any Executive Session. The date of the next meeting was set for 29, 30 July at Sunnyvale, California and the present session adjourned.

19 JUL 64 - SF